

2017-DSE
PHY
PAPER 2

HONG KONG EXAMINATIONS AND ASSESSMENT AUTHORITY
HONG KONG DIPLOMA OF SECONDARY EDUCATION EXAMINATION 2017

PHYSICS PAPER 2

Question-Answer Book

11.45 am – 12.45 pm (1 hour)

This paper must be answered in English

INSTRUCTIONS

- (1) After the announcement of the start of the examination, you should first write your Candidate Number in the space provided on Page 1 and stick barcode labels in the spaces provided on Pages 1, 3, 5, 7 and 9.
- (2) This paper consists of **FOUR** sections, Sections A, B, C and D. Each section contains eight multiple-choice questions and one structured question which carries 10 marks. Attempt **ALL** questions in any **TWO** sections.
- (3) Write your answers to the structured questions in the **ANSWER BOOK** provided. For multiple-choice questions, blacken the appropriate circle with an HB pencil. You should mark only **ONE** answer for each question. If you mark more than one answer, you will receive **NO MARKS** for that question.
- (4) Graph paper and supplementary answer sheets will be provided on request. Write your candidate number, mark the question number box and stick a barcode label on each sheet, and fasten them with string **INSIDE** the Answer Book.
- (5) The Question-Answer Book and Answer Book will be collected **SEPARATELY** at the end of the examination.
- (6) The diagrams in this paper are **NOT** necessarily drawn to scale.
- (7) The last two pages of this Question-Answer Book contain a list of data, formulae and relationships which you may find useful.
- (8) No extra time will be given to candidates for sticking on the barcode labels or filling in the question number boxes after the 'Time is up' announcement.

Please stick the barcode label here

Candidate Number

--	--	--	--	--	--	--	--	--	--	--	--	--	--	--	--	--	--	--	--	--



* A 1 5 0 E 2 M C

Section A : Astronomy and Space Science

Q.1: Multiple-choice questions

1.1 Normally, Mars moves eastward in the sky throughout the year. In May and June 2016, retrograde motion of Mars was observed. Which of the following statements is/are correct ?

- (1) During that period, Mars moved westward in the sky.
- (2) Retrograde motion is observed because the Earth moves faster than Mars.
- (3) Ptolemy's geocentric model cannot explain the retrograde motion.

- | | | | | |
|---------------------|-----------------------|-----------------------|-----------------------|-----------------------|
| A. (1) only | A | B | C | D |
| B. (3) only | <input type="radio"/> | <input type="radio"/> | <input type="radio"/> | <input type="radio"/> |
| C. (1) and (2) only | | | | |
| D. (2) and (3) only | | | | |

1.2 Two astronauts are experiencing 'weightlessness' in a space station. The mass of the astronauts are 50 kg and 70 kg respectively. Which of the following statements is/are correct ?

- (1) No gravitational force is acting on the two astronauts by the Earth.
- (2) The net forces acting on the two astronauts are the same.
- (3) The two astronauts have the same acceleration.

- | | | | | |
|---------------------|-----------------------|-----------------------|-----------------------|-----------------------|
| A. (1) only | A | B | C | D |
| B. (3) only | <input type="radio"/> | <input type="radio"/> | <input type="radio"/> | <input type="radio"/> |
| C. (1) and (2) only | | | | |
| D. (2) and (3) only | | | | |

1.3 It is given that the Moon's radius is $0.273 R$, where R is the radius of the Earth. And the acceleration due to gravity on the Moon's surface is $\frac{1}{6} g$, where g is the acceleration due to gravity on the Earth's surface. If v is the escape velocity from the surface of the Earth, what is the escape velocity from the surface of the Moon ?

- | | | | | |
|--------------|-----------------------|-----------------------|-----------------------|-----------------------|
| A. $0.046 v$ | A | B | C | D |
| B. $0.167 v$ | <input type="radio"/> | <input type="radio"/> | <input type="radio"/> | <input type="radio"/> |
| C. $0.213 v$ | | | | |
| D. $0.273 v$ | | | | |

Please stick the barcode label here

- 1.4 The following shows two pictures of the same region of the sky taken in January and May of a certain year. P , Q , R , S and T are five stars.

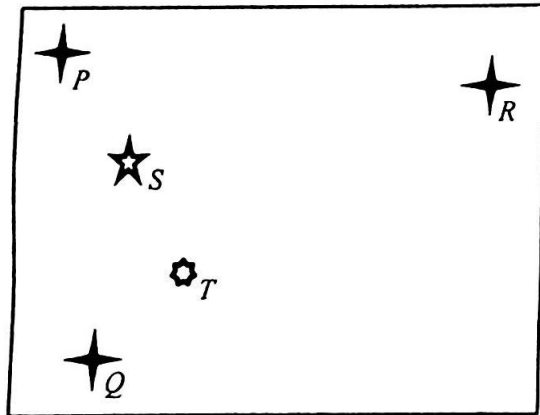

January view

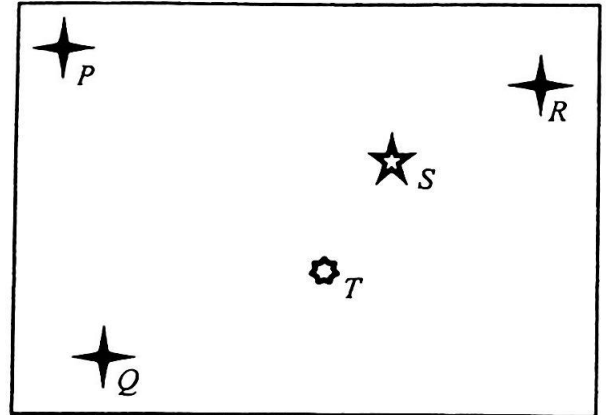

May view

Which of the following statements **MUST BE** correct?

- (1) Stars P , Q and R are equidistant from the Earth.
- (2) The parallax of star S is smaller than that of star T .
- (3) Star S is closer to the Earth than star T .

- A. (1) only
 B. (3) only
 C. (1) and (2) only
 D. (2) and (3) only

A B C D

- 1.5 The table below shows the apparent magnitudes and absolute magnitudes of three stars.

star	apparent magnitude	absolute magnitude
Sirius A	-1.47	1.42
Vega	0.03	0.58
Polaris A	1.98	-3.64

Which of the following is correct?

- | | greatest luminosity | farthest from the Earth | brightest as seen from the Earth |
|----|---------------------|-------------------------|----------------------------------|
| A. | Sirius A | Sirius A | Polaris A |
| B. | Sirius A | Vega | Sirius A |
| C. | Polaris A | Vega | Polaris A |
| D. | Polaris A | Polaris A | Sirius A |

A B C D

1.6 The diagram shows the spectra of radiation from a black body at two different temperatures, T_1 and T_2 .

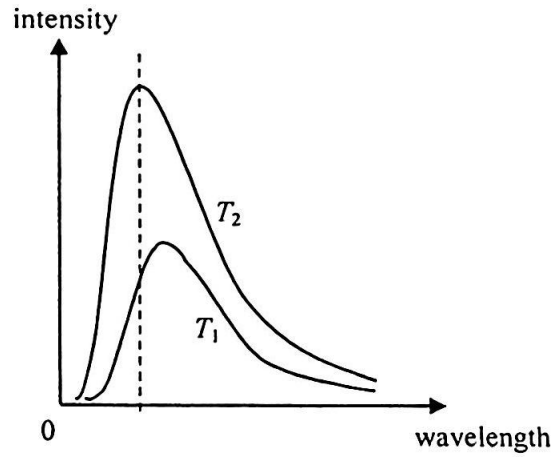

Which of the following is correct ?

	higher temperature	colour at T_2	A	B	C	D
A.	T_1	appears redder				
B.	T_1	appears bluer	<input type="radio"/>	<input type="radio"/>	<input type="radio"/>	<input type="radio"/>
C.	T_2	appears redder				
D.	T_2	appears bluer				

1.7 It is known that the Sun is a class G star, and the star Zeta Puppis is a class O supergiant. Which of the following is correct ?

Given: the sequence of the spectral classes is O B A F G K M.

	higher surface temperature	greater luminosity	A	B	C	D
A.	Zeta Puppis	Zeta Puppis				
B.	Zeta Puppis	the Sun	<input type="radio"/>	<input type="radio"/>	<input type="radio"/>	<input type="radio"/>
C.	the Sun	Zeta Puppis				
D.	the Sun	the Sun				

Please stick the barcode label here

1.8 The figure shows some information of stars X , Y and Z .

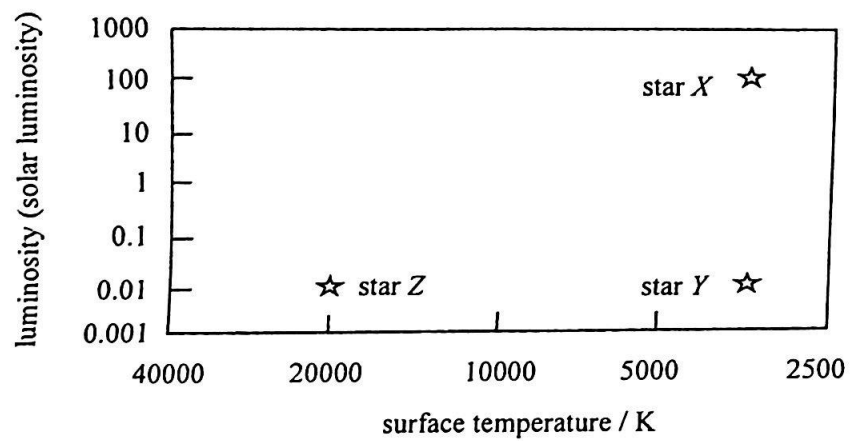

Which of the following comparisons about the size of the three stars is correct ?

- A. $X > Y > Z$
- B. $X = Y > Z$
- C. $X > Y = Z$
- D. $Z > Y > X$

- A
- B
- C
- D

Q.1: Structured question

- (a) Figure 1.1 shows an object of mass m orbiting around a star of mass M with a radius of r . The velocity of the object is v .

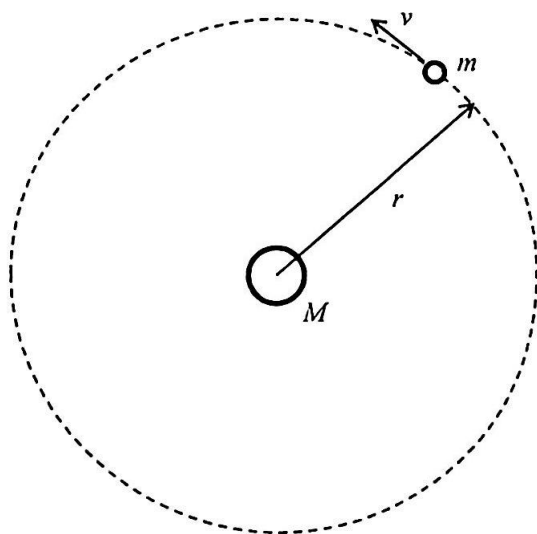

Figure 1.1

- (i) Using Newton's law of gravitation, show that

$$v^2 = \frac{GM}{r},$$

where G is the universal gravitational constant.

(1 mark)

- (ii) Hence, or otherwise, show that

$$T^2 = \frac{4\pi^2}{GM} r^3,$$

where T is the period of the motion of the object.

(2 marks)

- (b) Stars and gases orbit around the centre of the M33 Galaxy. At a position X near the edge of the galaxy (3.98×10^{20} m from the centre of the galaxy), the orbital velocity of the hydrogen gas is about 1.23×10^5 m s⁻¹. You may assume that the hydrogen gas at X orbits with a circular orbit.

- (i) One of the spectral lines of hydrogen gas (the H I line) has a wavelength of 21.106 cm. If the hydrogen gas at X is moving towards the Earth along the line of sight, what would be the observed wavelength of the H I line? (2 marks)

- (ii) How long would it take for the hydrogen gas at X to complete one orbit around the M33 Galaxy? (1 mark)

- (iii) Using the results of (a)(ii), or otherwise, estimate the mass of the M33 Galaxy in solar mass. Given: 1 AU = 1.50×10^{11} m, and 1 year = 3.16×10^7 s. (3 marks)

- (iv) Astronomers estimated that the total mass of luminous objects in the M33 Galaxy is 7×10^9 solar mass. Compare this to your answer in (b)(iii) and suggest a reason to explain the difference, if any. (1 mark)

Please stick the barcode label here

Section B : Atomic World

Q.2: Multiple-choice questions

2.1 Which of the following statements are correct according to Rutherford's atomic model ?

- (1) Almost all the mass of an atom are concentrated at the nucleus.
- (2) Almost all the charges of an atom are concentrated at the nucleus.
- (3) Electrons orbit around the nucleus.

- A. (1) and (2) only
- B. (1) and (3) only
- C. (2) and (3) only
- D. (1), (2) and (3)

- | | | | |
|-----------------------|-----------------------|-----------------------|-----------------------|
| A | B | C | D |
| <input type="radio"/> | <input type="radio"/> | <input type="radio"/> | <input type="radio"/> |

2.2

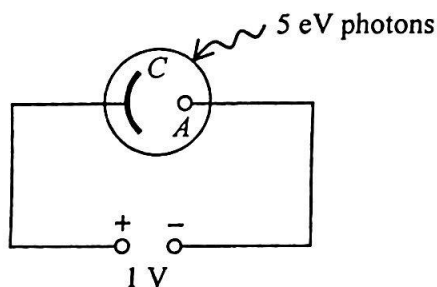

A photocell is connected to a 1 V d.c. source as shown. A monochromatic light beam with each photon of energy 5 eV is incident on cathode *C* of the photocell so that photoelectrons are emitted. If the work function of cathode *C* is 2 eV, what is the maximum kinetic energy of the photoelectrons reaching anode *A* ?

- A. 2 eV
- B. 3 eV
- C. 4 eV
- D. 6 eV

- | | | | |
|-----------------------|-----------------------|-----------------------|-----------------------|
| A | B | C | D |
| <input type="radio"/> | <input type="radio"/> | <input type="radio"/> | <input type="radio"/> |

2.3 When monochromatic light of wavelengths λ and $\frac{3}{4}\lambda$ are incident on the cathode surface of a photocell separately, the stopping potentials are in the ratio of 1 : 2. What is the longest wavelength of monochromatic light that can cause photoelectrons to be emitted from the photocell ?

- A. λ
- B. $\frac{4}{3}\lambda$
- C. $\frac{3}{2}\lambda$
- D. $\frac{5}{3}\lambda$

- | | | | |
|-----------------------|-----------------------|-----------------------|-----------------------|
| A | B | C | D |
| <input type="radio"/> | <input type="radio"/> | <input type="radio"/> | <input type="radio"/> |

2.4 A parallel beam of yellow light from a sodium discharge tube is directed to a glass tube filled with sodium vapour. Which of the following would happen after the sodium vapour absorbs the yellow light ?

- A. No more yellow light can be seen.
- B. The sodium vapour emits yellow light in the direction of the incident beam.
- C. The sodium vapour emits yellow light in all directions.
- D. The sodium vapour emits white light in all directions.

A B C D

2.5 A beam of 8 keV electrons is directed towards a crystal to observe the diffraction of electrons. What is the de Broglie wavelength of a 8 keV electron ?

- A. 4.34×10^{-10} m
- B. 1.37×10^{-11} m
- C. 1.74×10^{-19} m
- D. 5.49×10^{-21} m

A B C D

2.6 The radio telescope situated in Guizhou province has an effective aperture of 300 m for observations. It can be used to observe electromagnetic waves of frequencies between 7×10^7 Hz and 3×10^9 Hz. Estimate the minimum angular separation that the telescope can resolve.

- A. 4.07×10^{-4} rad
- B. 9.49×10^{-4} rad
- C. 1.74×10^{-2} rad
- D. 4.07×10^{-2} rad

A B C D

2.7 The leaves of the plant Edelweiss are covered with nanoscale filaments. These filaments absorb ultraviolet radiation but reflect all visible light. Which of the following statements are correct ?

- (1) The leaves appear white in colour under sunlight as the filaments reflect all visible light.
- (2) Optical microscopes cannot be used to observe the filaments.
- (3) Due to their tiny size, the filaments do not pose a health risk if absorbed into the human body.

- A. (1) and (2) only
- B. (1) and (3) only
- C. (2) and (3) only
- D. (1), (2) and (3)

A B C D

Please stick the barcode label here

A scanning tunneling microscope (STM) scans across a sample surface as shown. The probe scans across a small area of height h at a fixed height.

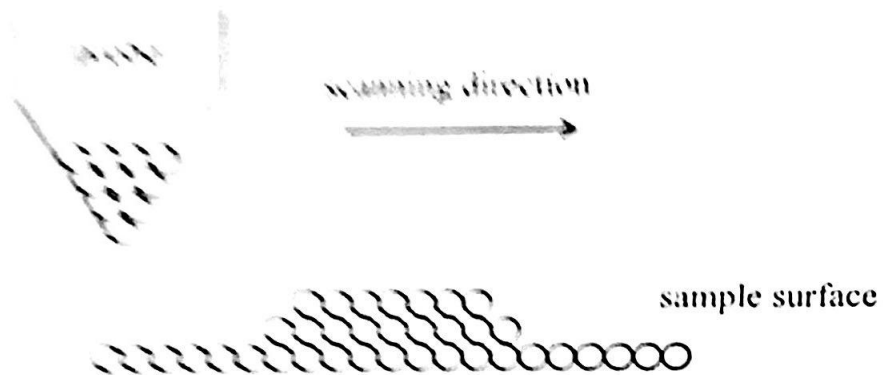

The graph below represents the variation of the tunnelling current with distance travelled by the probe.

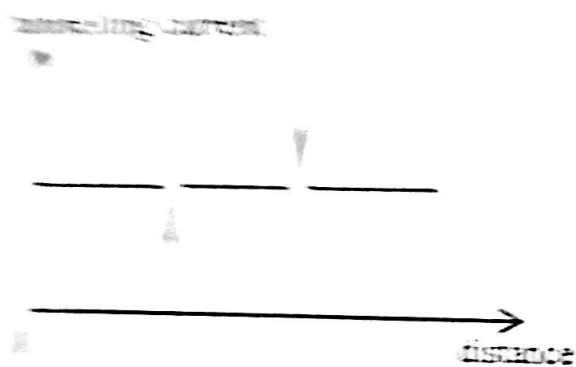

B.

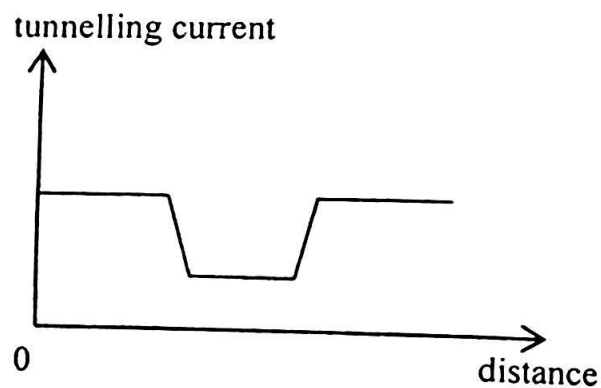

D.

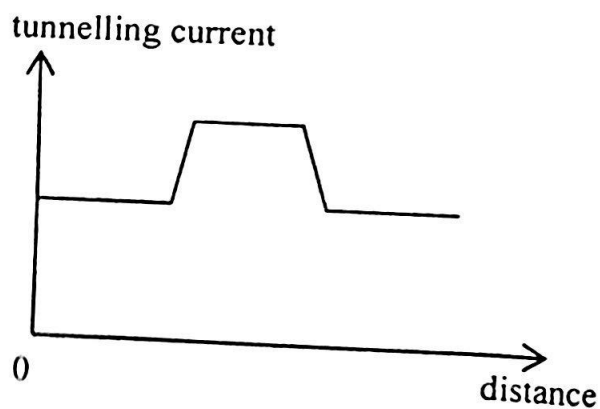

- A B C D

Q.2: Structured question

Figure 2.1 shows part of the line spectrum of hydrogen.

Figure 2.1

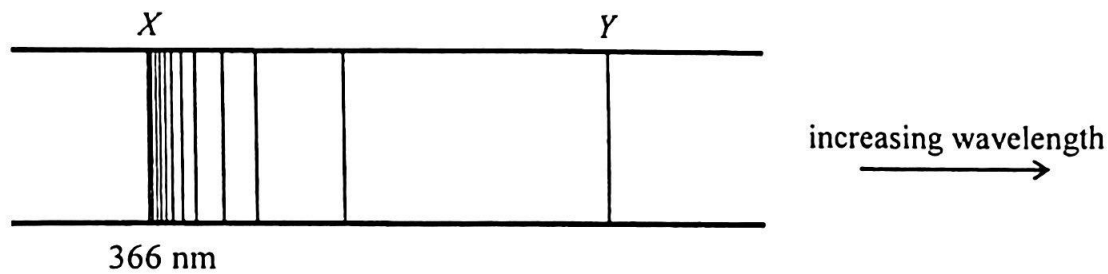

It contains a series of spectral lines with wavelength λ given by

$$\frac{1}{\lambda} = R\left(\frac{1}{2^2} - \frac{1}{n^2}\right),$$

where R is a constant and $n = 3, 4, 5, \dots$. There are no spectral lines in the series with wavelength less than that of line X (366 nm) nor greater than that of line Y .

- (a) Use Bohr's model of the hydrogen atom to explain why the spectral lines are discrete but not continuous. (2 marks)
- (b) (i) Which region of the electromagnetic spectrum does line X belong to? (1 mark)
- (ii) What is the energy of a photon of line X ? Express your answer in eV. (2 marks)
- (iii) What would happen when a beam of radiation having the same wavelength as line X is incident on hydrogen atoms in the first excited state ($n = 2$)? Briefly explain. (2 marks)
- (c) (i) State the transition in a hydrogen atom that can produce line Y . (1 mark)
- (ii) Determine the wavelength of line Y . (2 marks)

Section C : Energy and Use of Energy

Q.3: Multiple-choice questions

- 3.1 A street lamp is installed 10 m above the ground on the side of a road. At a point X which is 5 m from the side on the road surface, the illuminance is 30 lux.

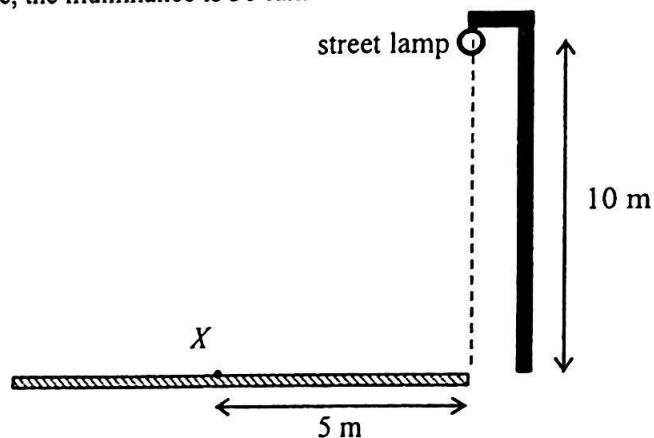

Taking the lamp as a point source emitting light uniformly in all directions, and neglecting the reflections and contributions from other light sources, estimate the luminous flux of the street lamp.

- A. 4.21×10^4 lm
 B. 5.27×10^4 lm
 C. 5.80×10^4 lm
 D. 6.59×10^4 lm

A B C D

- 3.2 Arrange the efficacy of the following light sources from the largest to the smallest.

	X	Y	Z
rated power	11 W	13 W	20 W
luminous flux	300 lm	400 lm	500 lm

- A. X, Y, Z
 B. X, Z, Y
 C. Y, X, Z
 D. Y, Z, X

A B C D

- 3.3 The surface of an induction cooker is usually made of strengthened glass. The glass surface gets hot after use mainly because

- A. an induction cooker has a high energy efficiency.
 B. heat is transferred from the cooking utensil to the glass surface when the cooking utensil gets hot.
 C. an eddy current flows in the glass.
 D. heat is produced in the solenoid of the cooker.

A B C D

3.4 Which of the following changes **WILL NOT** reduce the Overall Thermal Transfer Value (OTTV) of a building ?

- | | | | | |
|---|-----------------------|-----------------------|-----------------------|-----------------------|
| A. building a roof-top garden | A | B | C | D |
| B. installing heat insulating materials on the walls | <input type="radio"/> | <input type="radio"/> | <input type="radio"/> | <input type="radio"/> |
| C. adding solar control window films to the windows | | | | |
| D. painting the exterior of the building in dark colour | | | | |

3.5 A solar panel of area 3 m^2 is installed on a roof. Sunlight makes an angle of 20° to the normal of the panel at noon. The solar constant is 1366 W m^{-2} and 40% of the radiation power is absorbed by the atmosphere.

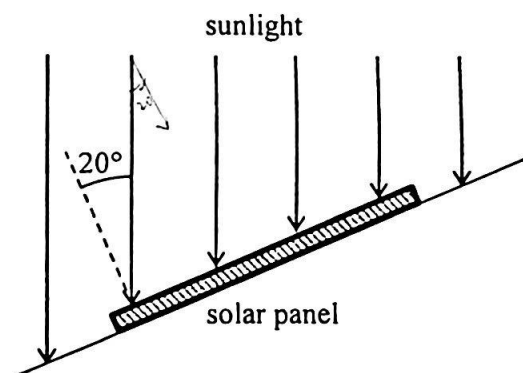

If the efficiency of the solar panel is 10%, what is the electrical power generated by it at noon ?

- | | | | | |
|----------|-----------------------|-----------------------|-----------------------|-----------------------|
| A. 84 W | A | B | C | D |
| B. 154 W | <input type="radio"/> | <input type="radio"/> | <input type="radio"/> | <input type="radio"/> |
| C. 231 W | | | | |
| D. 246 W | | | | |

3.6 The figure shows a wind turbine.

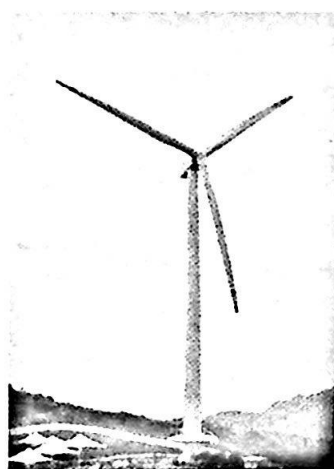

Which of the following statements explain why the wind turbine is **NOT** 100% efficient in converting the kinetic energy of the wind to electrical energy ?

- (1) There are mechanical energy losses in the moving parts.
- (2) Wind does not stop completely after passing through the rotor.
- (3) The direction of wind changes irregularly.

- | | | | | |
|---------------------|-----------------------|-----------------------|-----------------------|-----------------------|
| A. (1) and (2) only | A | B | C | D |
| B. (1) and (3) only | <input type="radio"/> | <input type="radio"/> | <input type="radio"/> | <input type="radio"/> |
| C. (2) and (3) only | | | | |
| D. (1), (2) and (3) | | | | |

3. The hydroelectric power plant shown has an efficiency of 40% in electricity generation. If the flow rate of the water is $20 \text{ m}^3 \text{ s}^{-1}$, what is the power output of the plant?
 Given density of water is 1000 kg m^{-3} . Take $g = 9.81 \text{ m s}^{-2}$.

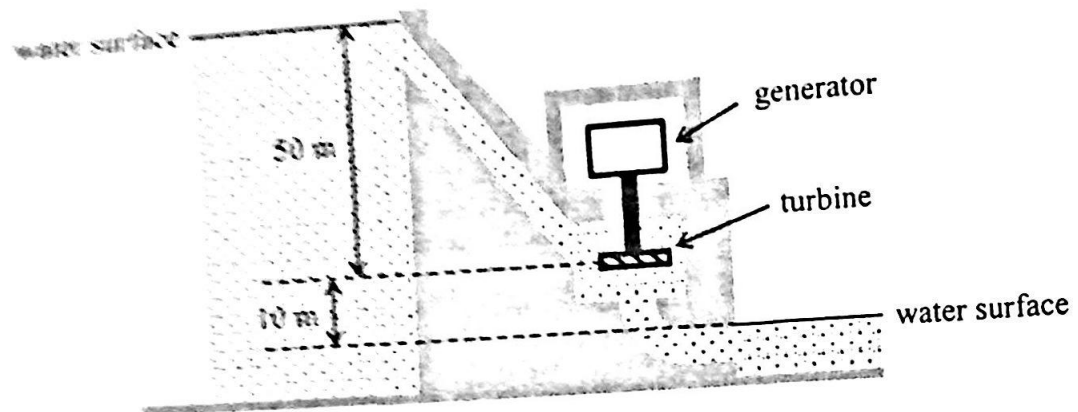

- A. 11.8 MW
- B. 55.4 MW
- C. 70.6 MW
- D. 88.5 MW

- A
- B
- C
- D

3.8 Energy is released in the following nuclear fission of uranium-235.

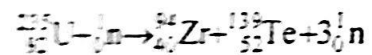

Which of the following statements concerning the reaction is/are correct?

- (1) The rate of the reaction can be controlled by absorbing some of the neutrons produced.
- (2) Mass is conserved in the reaction.
- (3) The binding energy per nucleon of ${}_{92}^{235}\text{U}$ is higher than that of ${}_{40}^{94}\text{Zr}$ or ${}_{52}^{139}\text{Te}$.

- A. (1) only
- B. (3) only
- C. (1) and (2) only
- D. (2) and (3) only

- A
- B
- C
- D

Q.3: Structured question

A refrigerated truck is used for transporting frozen goods. A refrigerator is installed in the refrigerated compartment.

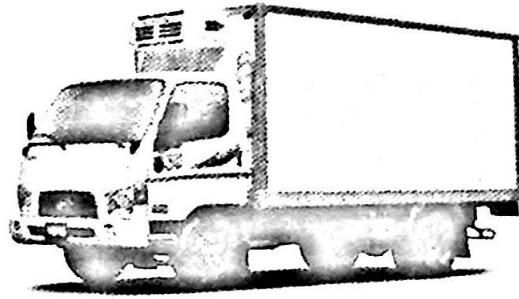

(a) Figure 3.1 shows a simplified schematic diagram of a refrigerator.

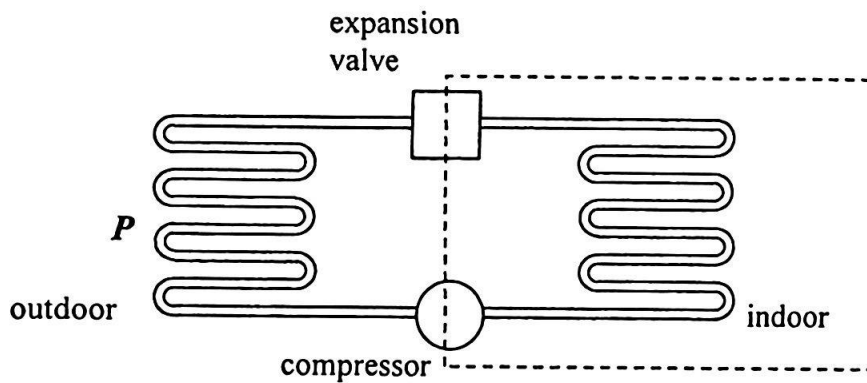

Figure 3.1

- In which direction does the refrigerant flow through the compressor (from indoor to outdoor or from outdoor to indoor)? (1 mark)
 - Describe the change of state of the refrigerant and the heat exchange when it flows through component P . (2 marks)
- (b) Figure 3.2 shows the dimensions of the refrigerated compartment. The compartment is insulated using 0.08 m thick polystyrene. The thermal conductivity of polystyrene is $0.03 \text{ W m}^{-1} \text{ K}^{-1}$.

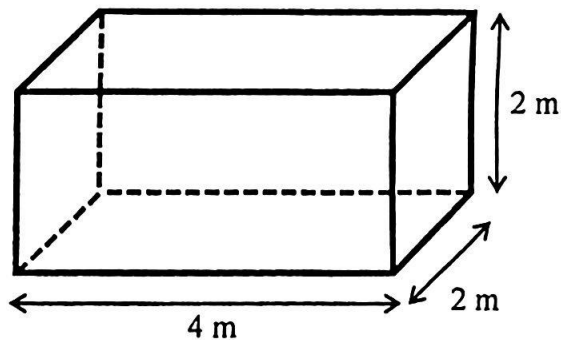

Figure 3.2

- If a temperature difference of 50°C is maintained between the exterior and the interior surfaces, estimate the minimum cooling capacity required for the refrigerator. (Hint: consider all the surfaces of the compartment.) (3 marks)
 - On a sunny afternoon, the **AIR TEMPERATURE** is 35°C . By using the refrigerator with cooling capacity calculated in (b)(i), briefly explain why the temperature inside the compartment **CANNOT** be maintained at -15°C . (2 marks)
- (c) Light emitting diodes (LED) are installed inside the refrigerated compartment for illumination. State **TWO** advantages of using LED over other common types of lighting. (2 marks)

Section D : Medical Physics

Q.4: Multiple-choice questions

4.1 The figure shows an eye looking at a distant object.

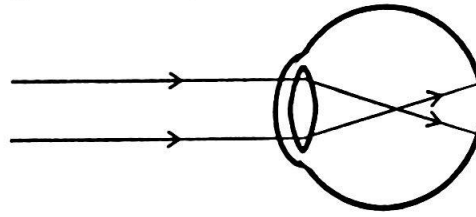

Which of the following is correct ?

	lens of the eye	corrected by wearing spectacles with	A	B	C	D
A.	too thick	diverging lens	<input type="radio"/>	<input type="radio"/>	<input type="radio"/>	<input type="radio"/>
B.	too thick	converging lens	<input type="radio"/>	<input type="radio"/>	<input type="radio"/>	<input type="radio"/>
C.	too thin	diverging lens	<input type="radio"/>	<input type="radio"/>	<input type="radio"/>	<input type="radio"/>
D.	too thin	converging lens	<input type="radio"/>	<input type="radio"/>	<input type="radio"/>	<input type="radio"/>

4.2 Which of the following statements about human hearing are correct ?

- (1) The ear bones in the middle ear convert sound waves into vibrations of the ear drum.
- (2) Pressure is amplified because of the difference in area between the ear drum and the oval window.
- (3) Mechanical vibrations are converted into electrical signals in the inner ear.

A.	(1) and (2) only	A	B	C	D
B.	(1) and (3) only	<input type="radio"/>	<input type="radio"/>	<input type="radio"/>	<input type="radio"/>
C.	(2) and (3) only	<input type="radio"/>	<input type="radio"/>	<input type="radio"/>	<input type="radio"/>
D.	(1), (2) and (3)	<input type="radio"/>	<input type="radio"/>	<input type="radio"/>	<input type="radio"/>

4.3 The sound intensity level in a factory is 95 dB. The workers in the factory wear ear protectors that can reduce the sound intensity level by 30 dB. What is the intensity of sound as heard by the workers ?

Given: the threshold of hearing $I_0 = 1 \times 10^{-12} \text{ W m}^{-2}$

A.	$1.00 \times 10^{-9} \text{ W m}^{-2}$	A	B	C	D
B.	$3.16 \times 10^{-6} \text{ W m}^{-2}$	<input type="radio"/>	<input type="radio"/>	<input type="radio"/>	<input type="radio"/>
C.	$3.16 \times 10^{-3} \text{ W m}^{-2}$	<input type="radio"/>	<input type="radio"/>	<input type="radio"/>	<input type="radio"/>
D.	3.16 W m^{-2}	<input type="radio"/>	<input type="radio"/>	<input type="radio"/>	<input type="radio"/>

4.4 The acoustic impedances of various tissues and that of air are listed in the following table.

	acoustic impedance ($\times 10^6 \text{ kg m}^{-2} \text{ s}^{-1}$)
fat	1.34
liver	1.65
muscle	1.71
bone	7.8
air	0.0004

Which of the following interface will give the largest intensity reflection coefficient in ultrasound scans ?

- | | | | | |
|-------------------|-----------------------|-----------------------|-----------------------|-----------------------|
| A. liver – muscle | A | B | C | D |
| B. fat – muscle | <input type="radio"/> | <input type="radio"/> | <input type="radio"/> | <input type="radio"/> |
| C. muscle – bone | | | | |
| D. muscle – air | | | | |

4.5 An ultrasound transducer is used to scan the eye (Figure 4.5.1) and the echoes received are shown in Figure 4.5.2. The velocity of the ultrasound waves in the eye is 1550 m s^{-1} .

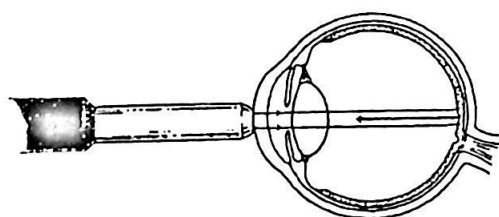

Figure 4.5.1

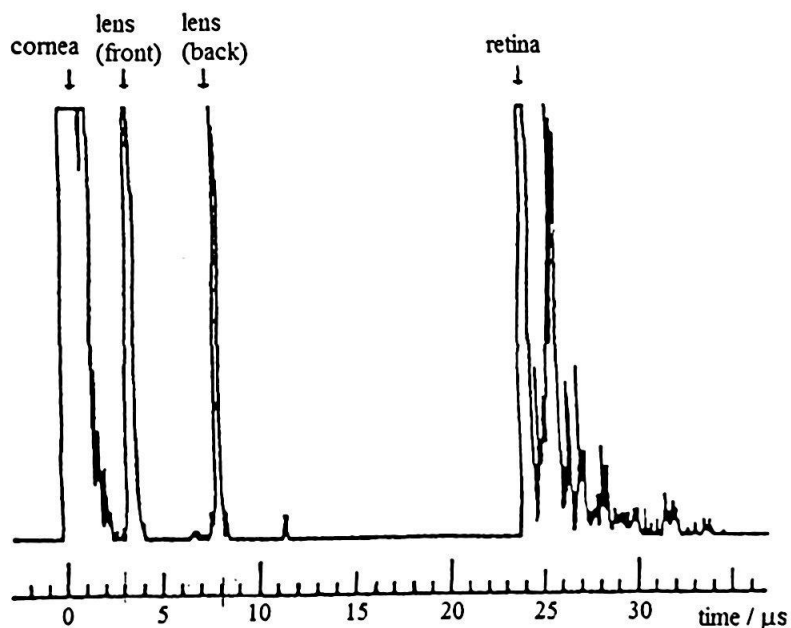

Figure 4.5.2

The thickness of the lens is about

- | | | | | |
|--------------|-----------------------|-----------------------|-----------------------|-----------------------|
| A. 1.6 mm . | A | B | C | D |
| B. 3.5 mm . | <input type="radio"/> | <input type="radio"/> | <input type="radio"/> | <input type="radio"/> |
| C. 7.0 mm . | | | | |
| D. 18.6 mm . | | | | |

4.6 Which of the following statements about an endoscope is correct ?

- A. Coherent bundle fibers are used to transmit image.
- B. Light can only travel from the objective to the eyepiece, but not in the opposite direction.
- C. The refractive index of the cladding of the glass fiber is higher than that of glass.
- D. An endoscope can only show black-and-white images.

A B C D

4.7 A certain tracer Y has a biological half-life of 3 days and a physical half-life of 4 hours. What is the effective half-life of Y ?

- A. 0.24 hours
- B. 1.71 hours
- C. 3.79 hours
- D. 4.23 hours

A B C D

4.8 Which of the following statements about radionuclide imaging is correct ?

- A. Due to the decay of the tracer, images should be taken immediately after the tracer is injected.
- B. The gamma camera emits gamma radiation to irradiate the tracer.
- C. Radionuclide imaging can clearly reveal the structure of a failed organ.
- D. For a period of time after injecting the tracer, excretion of the patient may be radioactive.

A B C D

Q.4: Structured question

X-ray radiographic imaging and computed tomography (CT) scans are used for medical purposes.

- (a) Briefly describe how X-ray is produced. (1 mark)
- (b) State an advantage of a CT scan over X-ray radiographic imaging. (1 mark)
- (c) The effective dose of radiation absorbed can be measured in millisieverts (mSv) or expressed as the time taken to receive the equivalent dose from background radiation. The effective doses for a chest X-ray radiographic imaging and a chest CT scan are shown below.

	effective dose (mSv)	equivalent background radiation dose (days)
chest X-ray radiographic imaging	0.02	1.85
chest CT scan	6.6	610.5

- (i) Briefly explain why the effective dose of a CT scan is much higher. (1 mark)
- (ii) A head CT scan has an effective dose of 1.5 mSv. Based on the information from the table, estimate its equivalent background radiation dose. (1 mark)
- (d) In a CT scan, a narrow X-ray beam of initial intensity I_0 transmits through lung cavity, soft tissue and bone along its path. The table below shows the linear attenuation coefficients of the tissues, and the path lengths of the X-ray in the tissues.

	linear attenuation coefficient (cm^{-1})	path length (cm)
lung cavity	0.1	19.8
soft tissue	0.18	8.8
bone	0.48	4.4

- (i) Briefly explain the large difference in linear attenuation coefficient between lung cavity and bone. (1 mark)
- (ii) Determine the value of $\frac{\text{transmitted intensity } I}{\text{initial intensity } I_0}$ of the X-ray after transmitted through lung cavity, soft tissue and bone. (3 marks)
- (e) A student suggests that a CT scan can be used for checking a foetus. Briefly explain whether you agree or not. If you do not agree, suggest a suitable medical imaging method for checking a foetus. (2 marks)

END OF PAPER

Sources of materials used in this paper will be acknowledged in the booklet *HKDSE Question Papers* published by the Hong Kong Examinations and Assessment Authority at a later stage.