

HONG KONG EXAMINATIONS AND ASSESSMENT AUTHORITY  
HONG KONG DIPLOMA OF SECONDARY EDUCATION EXAMINATION 2013

**PHYSICS PAPER 1**

8.30 am – 11.00 am (2½ hours)

This paper must be answered in English

**GENERAL INSTRUCTIONS**

- (1) There are **TWO** sections, A and B, in this Paper. You are advised to finish Section A in about 60 minutes.
- (2) Section A consists of multiple-choice questions in this question paper, while Section B contains conventional questions printed separately in Question-Answer Book B.
- (3) Answers to Section A should be marked on the Multiple-choice Answer Sheet while answers to Section B should be written in the spaces provided in the Question-Answer Book. **The Answer Sheet for Section A and the Question-Answer Book for Section B will be collected separately at the end of the examination.**
- (4) The diagrams in this paper are **NOT** necessarily drawn to scale.
- (5) The last two pages of this question paper contain a list of data, formulae and relationships which you may find useful.

---

**INSTRUCTIONS FOR SECTION A (MULTIPLE-CHOICE QUESTIONS)**

- (1) Read carefully the instructions on the Answer Sheet. After the announcement of the start of the examination, you should first stick a barcode label and insert the information required in the spaces provided. No extra time will be given for sticking on the barcode label after the 'Time is up' announcement.
- (2) When told to open this book, you should check that all the questions are there. Look for the words '**END OF SECTION A**' after the last question.
- (3) All questions carry equal marks.
- (4) **ANSWER ALL QUESTIONS.** You are advised to use an HB pencil to mark all the answers on the Answer Sheet, so that wrong marks can be completely erased with a rubber. You must mark the answers clearly; otherwise you will lose marks if the answers cannot be captured.
- (5) You should mark only **ONE** answer for each question. If you mark more than one answer, you will receive **NO MARKS** for that question.
- (6) No marks will be deducted for wrong answers.

Not to be taken away before the  
end of the examination session

## Section A

There are 36 questions. Questions marked with \* involve knowledge of the extension component.

1. Which of the following statements about *boiling* and *evaporation* of a liquid is/are correct ?
- (1) A liquid absorbs energy when it boils but does not absorb energy when it evaporates.
  - (2) Boiling occurs at a definite temperature while evaporation takes place above room temperature.
  - (3) Boiling occurs throughout the liquid while evaporation only takes place at the liquid's surface.
- A. (1) only  
B. (3) only  
C. (1) and (2) only  
D. (2) and (3) only
2. In an experiment to measure the specific latent heat of vaporization of water, a beaker of water is boiled off using an electric heater. Which of the following sources of error would lead to an experimental result smaller than the standard value ?
- A. Energy is lost to the surroundings.  
B. Water splashes out of the beaker.  
C. Steam condenses on the cooler part of the heater and drops back to the beaker.  
D. The heater is not completely immersed in water.
- \*3. In which of the following situations would the r.m.s. speed of the molecules of a fixed mass of an ideal gas increase ?
- (1) The gas is heated under constant volume.
  - (2) The gas expands under constant pressure.
  - (3) The gas is compressed under constant temperature.
- A. (1) only  
B. (3) only  
C. (1) and (2) only  
D. (2) and (3) only

\*4.

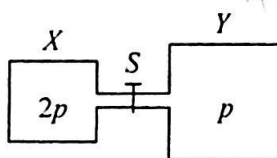

Vessel  $X$  of volume  $V$  and vessel  $Y$  of volume  $2V$  are connected by a short narrow tube as shown. Initially, tap  $S$  is closed and the same kind of ideal gas at the same temperature is contained in  $X$  and  $Y$  at pressure  $2p$  and  $p$  respectively. The tap  $S$  is then opened and equilibrium state is finally reached with the temperature unchanged. Which statement is **INCORRECT** ?

- A. Before  $S$  is opened, both vessels contain the same number of gas molecules.  
B. Before  $S$  is opened, the average kinetic energy of the gas molecules in both vessels is the same.  
C. When  $S$  is opened, a net flow of gas from  $X$  to  $Y$  occurs.  
D. When equilibrium is reached, the gas pressure becomes  $\frac{3}{2}p$ .

5.

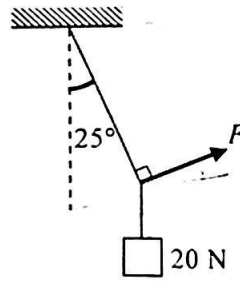

A block of weight 20 N is suspended by a light string from the ceiling. A force  $F$  is applied such that the block is displaced to one side with the string making an angle of  $25^\circ$  with the vertical as shown. Find the magnitude of  $F$ .

- A. 8.5 N
- B. 9.3 N
- C. 18.1 N
- D. 47.3 N

6.

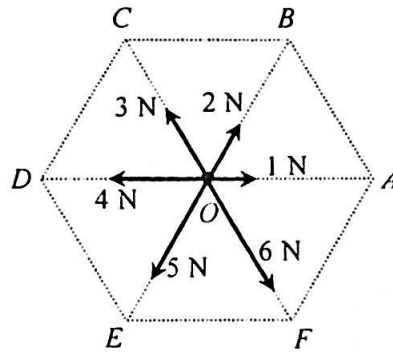

In the figure,  $O$  is the centre of a regular hexagon. A particle at  $O$  is subject to six forces with magnitudes indicated as shown. The resultant force acting on the particle is

- A. 9 N along direction  $OE$ .
- B. 8 N along direction  $OE$ .
- C. 8 N along direction  $OF$ .
- D. 6 N along direction  $OE$ .

7.

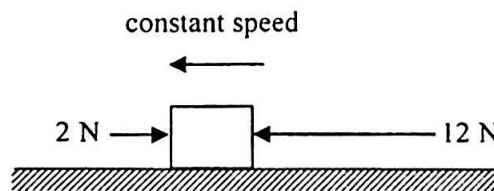

A block on a rough horizontal surface is moving to the left with constant speed under two horizontal forces 2 N and 12 N indicated as shown. If the force of 12 N is suddenly removed, what is the net force acting on the block at that instant?

- A. 12 N
- B. 10 N
- C. 8 N
- D. 2 N

8.

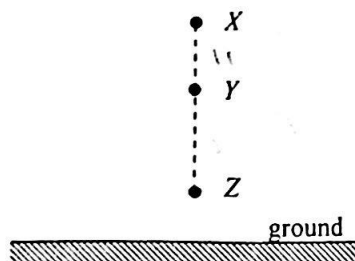

A particle is released from rest at  $X$  as shown. It takes time  $t_1$  to fall from  $X$  to  $Y$  and time  $t_2$  to fall from  $Y$  to  $Z$ . If  $XY : YZ = 9 : 16$ , find  $t_1 : t_2$ . Neglect air resistance.

- A. 2 : 3
- B. 3 : 4
- C. 4 : 3
- D. 3 : 2

9.

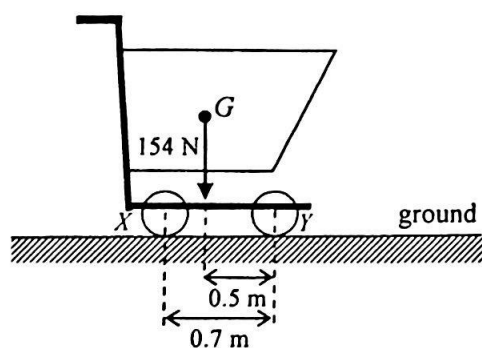

The figure shows a supermarket trolley resting on the ground. The separation between cylindrical wheels  $X$  and  $Y$  is  $0.7$  m. When the trolley is loaded to a total weight of  $154$  N, its centre of gravity  $G$  is at a horizontal distance of  $0.5$  m from the wheel  $Y$ . What is the reaction acting on the wheel  $X$  from the ground?

- A. 44 N
- B. 62 N
- C. 92 N
- D. 110 N

10.

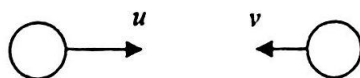

Two identical spheres are moving in opposite directions with speeds  $u$  and  $v$  (with  $u > v$ ) respectively as shown. They make a head-on collision. Which of the following diagrams show(s) a possible situation of the spheres after collision?

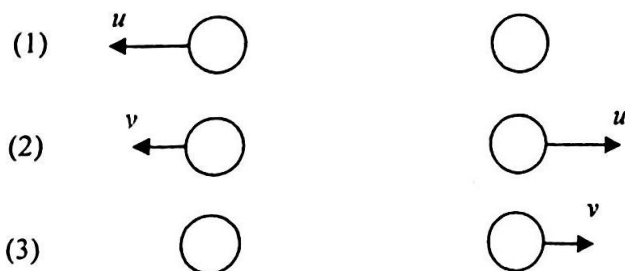

- A. (1) only
- B. (3) only
- C. (1) and (2) only
- D. (2) and (3) only

11. Two particles  $P$  and  $Q$  start from the same position and travel along the same straight line. The figure shows the velocity-time ( $v-t$ ) graph for  $P$  and  $Q$ . Which of the following descriptions about their motion is/are correct?

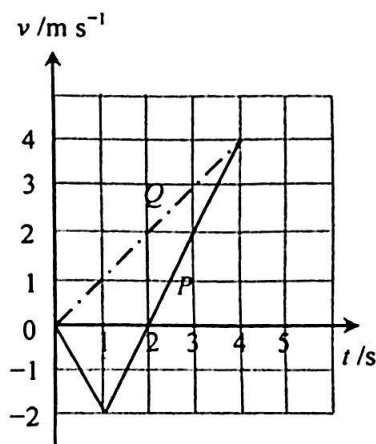

- (1) At  $t = 1$  s,  $P$  changes its direction of motion.  
 (2) At  $t = 2$  s, the separation between  $P$  and  $Q$  is 4 m.  
 (3) At  $t = 4$  s,  $P$  and  $Q$  meet each other.

- A. (1) only  
 B. (2) only  
 C. (1) and (3) only  
 D. (2) and (3) only

12.

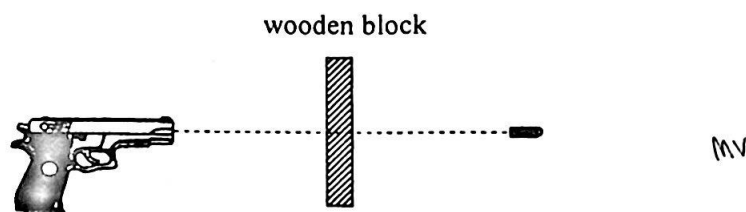

A bullet of mass  $50$  g is fired from a gun with a speed of  $400$  m s<sup>-1</sup> and passes right through a fixed wooden block of  $6$  cm thickness as shown. Find the average resistive force acting on the bullet due to the block if it emerges with a speed of  $250$  m s<sup>-1</sup>. Neglect air resistance and the effects of gravity.

- A.  $4.06 \times 10^4$  N  
 B.  $1.02 \times 10^4$  N  
 C.  $125$  N  
 D. Answer cannot be found as the time of travel of the bullet within the block is not known.

\*13.

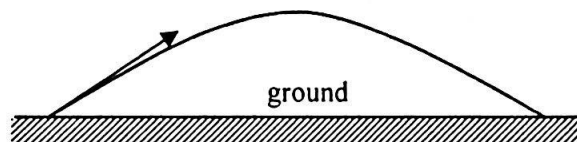

A particle is projected into the air at time  $t = 0$  and it performs a parabolic motion before landing on the ground as shown. Which graph represents the variation of the kinetic energy (KE) of the particle with time before landing? Neglect air resistance.

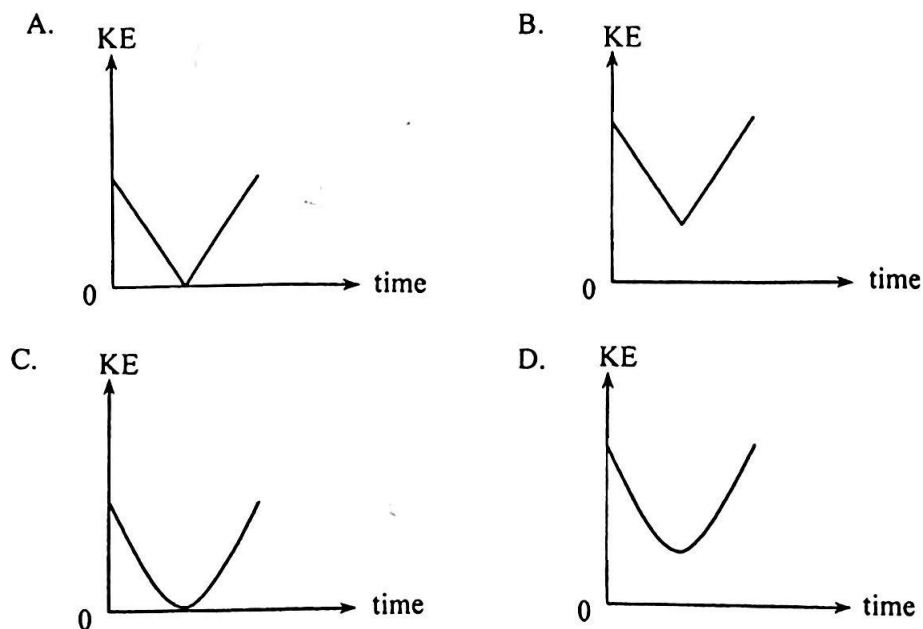

14.



A semi-circular cardboard hangs from a spring balance from point  $O$  as shown. The reading of the spring balance is  $5\text{ N}$ . Which statements are correct?

- (1) The weight of the cardboard is  $5\text{ N}$ .
- (2) The centre of gravity of the cardboard is directly under  $O$ . ✓
- (3) The reading of the balance would become zero if the set-up is brought to the Moon's surface.

- A. (1) and (2) only
- B. (1) and (3) only
- C. (2) and (3) only
- D. (1), (2) and (3)

- \*15. It is known that the mass of Mars is about  $\frac{1}{10}$  of that of the Earth while its radius is about  $\frac{1}{2}$  of the Earth's radius. In terms of the gravitational acceleration  $g$  on the Earth's surface, the approximate gravitational acceleration on the surface of Mars is

- A.  $0.2\text{ g}$ .
- B.  $0.4\text{ g}$ .
- C.  $2.5\text{ g}$ .
- D.  $4\text{ g}$ .

16.

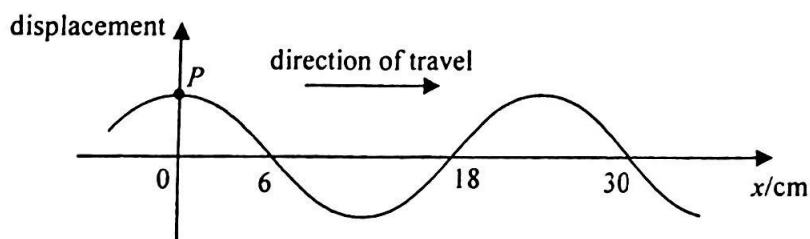

The figure shows a snapshot of a section of a continuous transverse wave travelling along the  $x$ -direction at time  $t = 0$ . At  $t = 1.5\text{ s}$ , the particle  $P$  just passes the equilibrium position for a *second* time at that moment. Find the wave speed.

- A.  $20\text{ cm s}^{-1}$
- B.  $12\text{ cm s}^{-1}$
- C.  $6\text{ cm s}^{-1}$
- D.  $4\text{ cm s}^{-1}$

17.

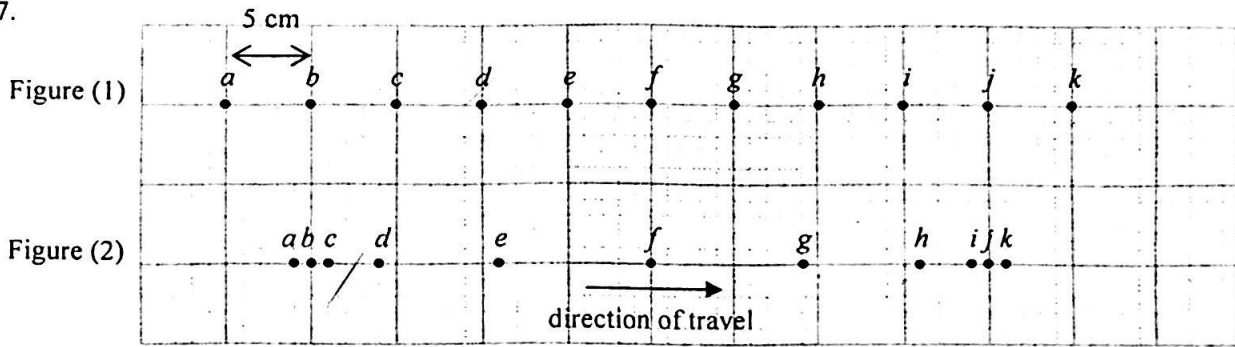
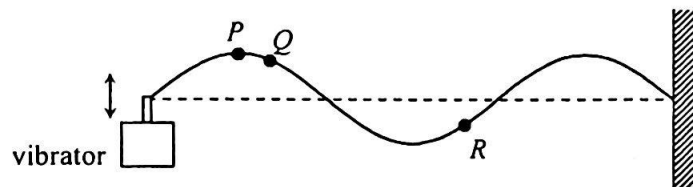

Figure (1) shows the equilibrium positions of particles *a* to *k* separated by 5 cm from each other in a medium. A longitudinal wave is travelling from left to right with a speed of  $80 \text{ cm s}^{-1}$ . At a certain instant, the positions of the particles are shown in Figure (2). Determine the amplitude and frequency of the wave.

	amplitude	frequency
A.	6 cm ✓	2 Hz ✓
B.	6 cm ✓	4 Hz
C.	9 cm	2 Hz ✓
D.	9 cm	4 Hz

18.



A vibrator generates a stationary wave on a string which is fixed at one end. The figure shows the appearance of the string at a certain instant. Which of the following descriptions about the motion of particles *P*, *Q* and *R* must be correct?

- (1) *P* and *Q* are momentarily at rest at this instant.
- (2) *Q* and *R* take the same time to reach their respective equilibrium positions.
- (3) *P* and *R* are always in antiphase.

- A. (1) only
- B. (3) only
- C. (1) and (2) only
- D. (2) and (3) only

19.

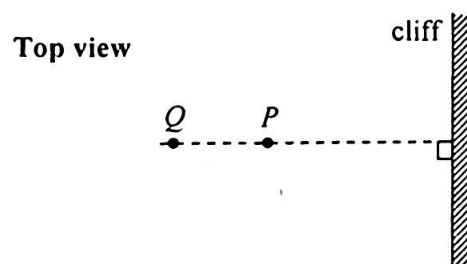

Astronauts *P* and *Q* stand at 400 m and 600 m respectively from a vertical cliff on the surface of a planet. The figure shows the top view. *P* claps his hands once and *Q* hears two clapping sounds separated by 4 s. What is the speed of sound in the atmosphere of this planet?

- A.  $100 \text{ m s}^{-1}$
- B.  $150 \text{ m s}^{-1}$
- C.  $200 \text{ m s}^{-1}$
- D.  $250 \text{ m s}^{-1}$

20.

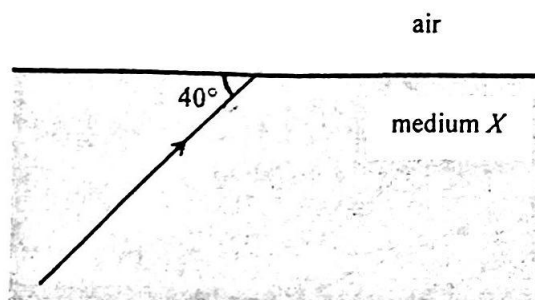

A ray of light is travelling from a transparent medium  $X$  to air making an angle of  $40^\circ$  with the boundary plane as shown. If the angle between the refracted ray in air and the reflected ray in medium  $X$  is  $70^\circ$ , find the refractive index of medium  $X$ .

- A.  $\frac{\sin 40^\circ}{\sin 30^\circ}$   
 B.  $\frac{\sin 30^\circ}{\sin 40^\circ}$   
 C.  $\frac{\sin 60^\circ}{\sin 50^\circ}$   
 D.  $\frac{\sin 50^\circ}{\sin 60^\circ}$

21. White light can be resolved into component colours by using a glass prism. Which of the following statements is/are correct?

- (1) The refractive indices of glass for different component colours are not the same.  
 (2) Red light travels faster than violet light in a vacuum.  
 (3) The frequencies of all the component colours are reduced when entering the prism.

- A. (1) only  
 B. (3) only  
 C. (1) and (2) only  
 D. (2) and (3) only

22.

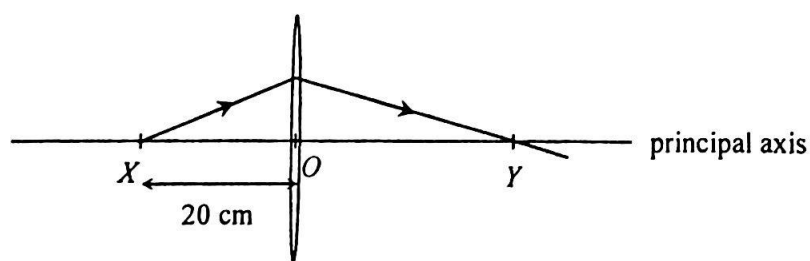

A point light source at  $X$  on the principal axis of a thin convex lens emits a ray of light. The ray passes through the lens and reaches the principal axis at point  $Y$  as shown.  $O$  is the optical centre of the lens such that  $OX = 20$  cm and  $OY > OX$ . Which of the following statements is/are correct?

- (1) The focal length of the lens is shorter than 20 cm.  
 (2) If the point light source is shifted away from the lens, separation  $OY$  would increase.  
 (3) An object placed at  $Y$  would give a diminished image at  $X$ .

- A. (1) only  
 B. (2) only  
 C. (1) and (3) only  
 D. (2) and (3) only



\*23.

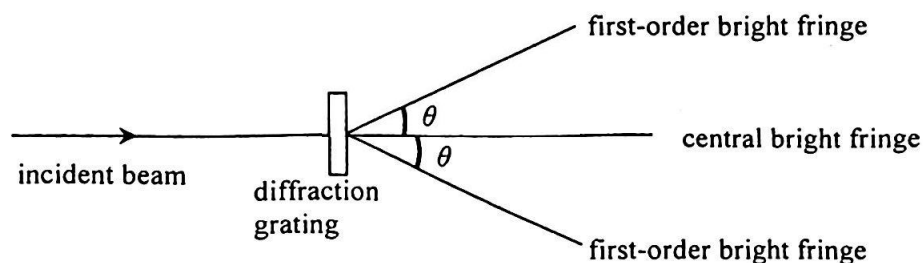

When monochromatic light passes through a diffraction grating, a pattern of bright fringes is formed. Which arrangement would produce the greatest angle  $\theta$  between the central and first-order bright fringes?

	grating (lines per mm)	colour of light
A.	400 ✓	green
B.	400 ✓	blue
C.	200	green
D.	200	blue

24.  $X$  and  $Y$  are two small identical metal spheres carrying charges  $-2Q$  and  $+6Q$  respectively. When  $X$  and  $Y$  are separated by a certain distance, the magnitude of the electrostatic force between them is  $F$ .

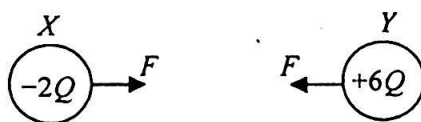

The spheres are brought to touch each other and then placed back to their original positions. The electrostatic force between them becomes

- A.  $\frac{1}{4}F$ , attractive.
- B.  $\frac{1}{4}F$ , repulsive.
- C.  $\frac{1}{3}F$ , attractive.
- D.  $\frac{1}{3}F$ , repulsive.

\*25. Lightning flash may occur when the strength of the electric field (assumed uniform) between a thundercloud and the ground reaches  $3 \times 10^6 \text{ N C}^{-1}$ . A lightning flash on average discharges about 20 C of charge. If a thundercloud is at a height of 500 m above the ground, estimate the order of magnitude of the energy released in a lightning flash.

- A.  $10^6 \text{ J}$
- B.  $10^8 \text{ J}$
- C.  $10^{10} \text{ J}$
- D.  $10^{12} \text{ J}$

26.

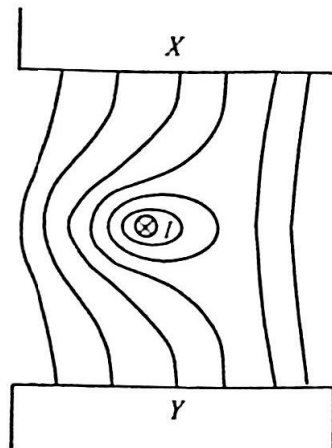

A straight wire carrying current  $I$  pointing into the paper is placed in a magnetic field between pole pieces  $X$  and  $Y$ . The figure shows the resultant field line pattern. What is the polarity of pole piece  $X$  and in what direction is the magnetic force acting on the wire? Ignore the effect of the Earth's magnetic field.

	polarity of $X$	direction of magnetic force
A.	N	to right
B.	N	to left
C.	S	to right
D.	S	to left

27.

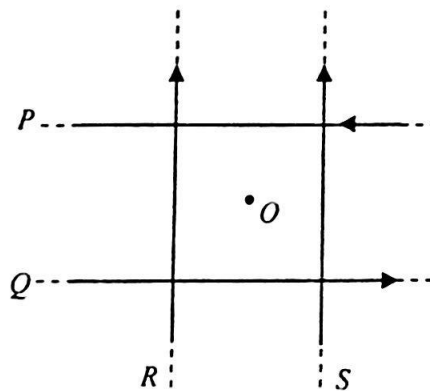

In the figure, four long straight wires  $P$ ,  $Q$ ,  $R$  and  $S$  in the same plane carry equal currents in the directions shown. The wires are insulated from each other.  $O$  is a point on the same plane and is equidistant from each wire. Removing which wire would increase the magnetic field strength at  $O$ ?

- A. wire  $P$
- B. wire  $Q$
- C. wire  $R$
- D. wire  $S$

28.

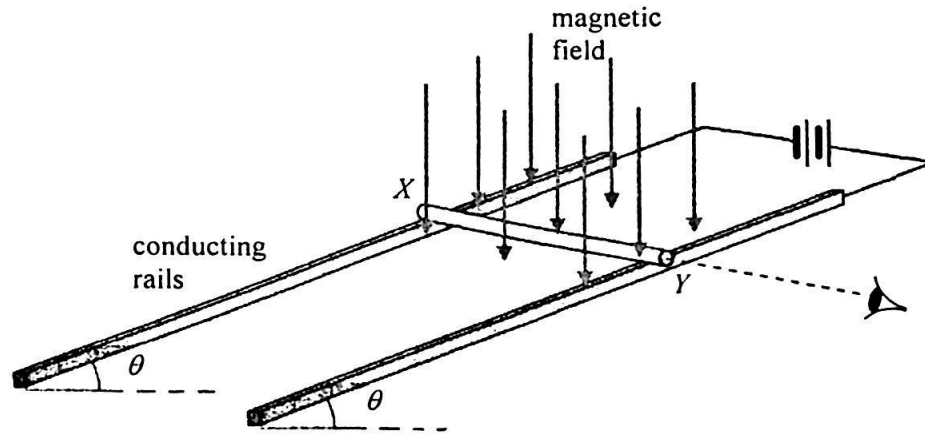

A copper rod  $XY$  is placed on a pair of smooth inclined conducting rails which are located in a magnetic field applied vertically downward. The rails make an angle  $\theta$  to the horizontal and a battery is connected to the rails as shown above. Which diagram shown below represents the magnetic force  $F_B$  acting on the rod when viewed from end  $Y$ ?

A.

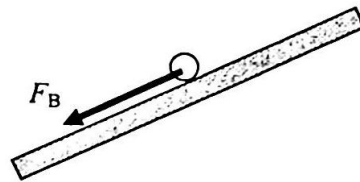

B.

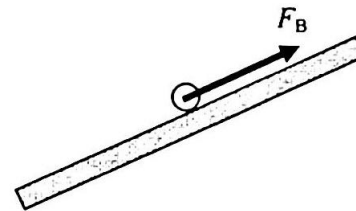

C.

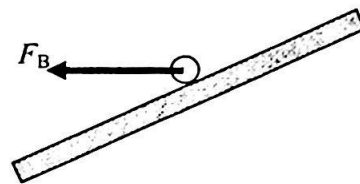

D.

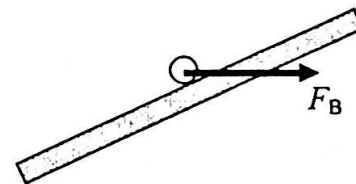

29.

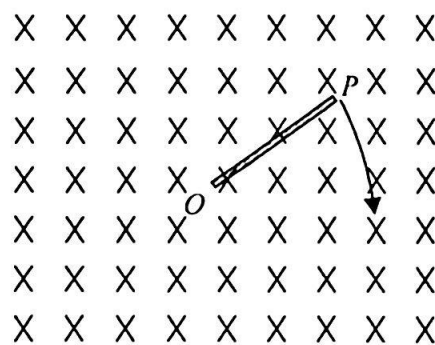

A metal rod  $OP$  is rotated about  $O$  in a clockwise direction in the plane of the paper with a uniform magnetic field pointing into the paper. Which statement is correct?

- A. An induced current flows in the rod from  $O$  to  $P$ .
- B. An induced current flows in the rod from  $P$  to  $O$ .
- C. E.m.f. is induced in the rod with end  $O$  at a higher electric potential.
- D. E.m.f. is induced in the rod with end  $P$  at a higher electric potential.

30.

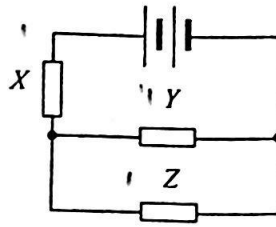

Resistors  $X$ ,  $Y$  and  $Z$  in the above circuit are identical while the battery of negligible internal resistance supplies a total power of 24 W. What is the power dissipated in resistor  $Z$ ?

- A. 3 W
- B. 4 W
- C. 6 W
- D. 8 W

31.

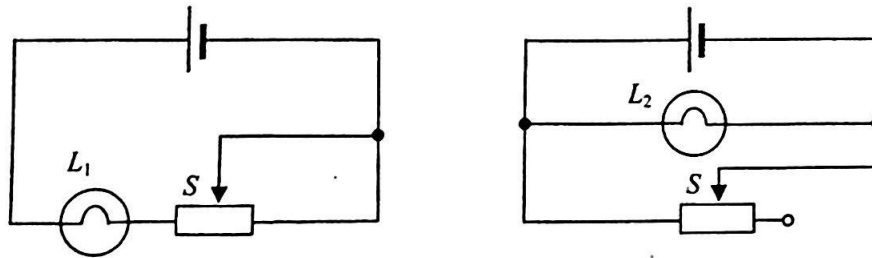

In each of the above circuits, the cell has constant e.m.f. and negligible internal resistance. When the sliding contact  $S$  of each rheostat shifts from the mid-position to the right, how would the brightness of each bulb change?

- |    | bulb $L_1$        | bulb $L_2$        |
|----|-------------------|-------------------|
| A. | becomes dimmer    | remains unchanged |
| B. | becomes dimmer    | becomes brighter  |
| C. | remains unchanged | becomes dimmer    |
| D. | becomes brighter  | remains unchanged |

32.

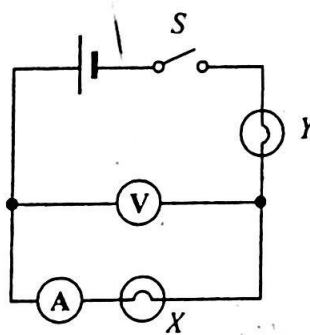

In the above circuit, the cell has negligible internal resistance. When switch  $S$  is closed, both bulbs are not lit. The voltmeter has a reading but the ammeter reads zero. If only one fault has been developed in the circuit, which of the following is possible?

- A. Bulb  $X$  has been shorted accidentally.
- B. Bulb  $Y$  has been shorted accidentally.
- C. Bulb  $X$  is burnt out and becomes open circuit.
- D. Bulb  $Y$  is burnt out and becomes open circuit.

33. Which of the following domestic electrical appliances consumes a power close to 1 kW in normal working conditions ?

- A. an electric fan
- B. a microwave oven
- C. a fluorescent lamp
- D. a TV set

34.  ${}_{92}^{238}\text{U}$  undergoes  $\alpha$ - $\beta$ - $\beta$ - $\alpha$  decay and becomes a nuclide  $X$ . What are the atomic number and mass number of  $X$  ?

	atomic number	mass number
A.	90	230
B.	90	234
C.	88	230
D.	88	234

\*35. Polonium-210 is a pure  $\alpha$ -emitter with a half-life of 140 days and it will decay into lead, which is stable. Initially there is a sample containing 420 mg of pure polonium-210. Estimate the mass of polonium-210 left after 70 days.

- A. 315 mg
- B. 297 mg
- C. 210 mg
- D. 105 mg

\*36. The sun releases huge amount of energy through thermonuclear fusion while at the same time its mass decreases. The average power released by the sun is about  $3.8 \times 10^{26}$  W. Estimate the decrease in mass of the sun in one second.

- A.  $4.2 \times 10^6$  kg
- B.  $4.2 \times 10^9$  kg
- C.  $1.3 \times 10^{15}$  kg
- D.  $1.3 \times 10^{18}$  kg

END OF SECTION A

**Blank page**

## List of data, formulae and relationships

### Data

molar gas constant	$R = 8.31 \text{ J mol}^{-1} \text{ K}^{-1}$	
Avogadro constant	$N_A = 6.02 \times 10^{23} \text{ mol}^{-1}$	
acceleration due to gravity	$g = 9.81 \text{ m s}^{-2}$ (close to the Earth)	
universal gravitational constant	$G = 6.67 \times 10^{-11} \text{ N m}^2 \text{ kg}^{-2}$	
speed of light in vacuum	$c = 3.00 \times 10^8 \text{ m s}^{-1}$	
charge of electron	$e = 1.60 \times 10^{-19} \text{ C}$	
electron rest mass	$m_e = 9.11 \times 10^{-31} \text{ kg}$	
permittivity of free space	$\epsilon_0 = 8.85 \times 10^{-12} \text{ C}^2 \text{ N}^{-1} \text{ m}^{-2}$	
permeability of free space	$\mu_0 = 4\pi \times 10^{-7} \text{ H m}^{-1}$	
atomic mass unit	$u = 1.661 \times 10^{-27} \text{ kg}$	(1 u is equivalent to 931 MeV)
astronomical unit	$\text{AU} = 1.50 \times 10^{11} \text{ m}$	
light year	$\text{ly} = 9.46 \times 10^{15} \text{ m}$	
parsec	$\text{pc} = 3.09 \times 10^{16} \text{ m} = 3.26 \text{ ly} = 206265 \text{ AU}$	
Stefan constant	$\sigma = 5.67 \times 10^{-8} \text{ W m}^{-2} \text{ K}^{-4}$	
Planck constant	$h = 6.63 \times 10^{-34} \text{ J s}$	

### Rectilinear motion

For uniformly accelerated motion :

$$v = u + at$$

$$s = ut + \frac{1}{2}at^2$$

$$v^2 = u^2 + 2as$$

### Mathematics

Equation of a straight line	$y = mx + c$
Arc length	$= r\theta$
Surface area of cylinder	$= 2\pi rh + 2\pi r^2$
Volume of cylinder	$= \pi r^2 h$
Surface area of sphere	$= 4\pi r^2$
Volume of sphere	$= \frac{4}{3}\pi r^3$

For small angles,  $\sin \theta \approx \tan \theta \approx \theta$  (in radians)

<p><b>Astronomy and Space Science</b></p> $U = -\frac{GMm}{r}$ <p style="text-align: right;">gravitational potential energy</p> $P = \sigma AT^4$ <p style="text-align: right;">Stefan's law</p> $\left  \frac{\Delta f}{f_0} \right  \approx \frac{v}{c} \approx \left  \frac{\Delta \lambda}{\lambda_0} \right $ <p style="text-align: right;">Doppler effect</p>	<p><b>Energy and Use of Energy</b></p> $E = \frac{\Phi}{A}$ <p style="text-align: right;">illuminance</p> $\frac{Q}{t} = \kappa \frac{A(T_H - T_C)}{d}$ <p style="text-align: right;">rate of energy transfer by conduction</p> $U = \frac{\kappa}{d}$ <p style="text-align: right;">thermal transmittance U-value</p> $P = \frac{1}{2} \rho A v^3$ <p style="text-align: right;">maximum power by wind turbine</p>
<p><b>Atomic World</b></p> $\frac{1}{2} m_e v_{\max}^2 = hf - \phi$ <p style="text-align: right;">Einstein's photoelectric equation</p> $E_n = -\frac{1}{n^2} \left\{ \frac{m_e e^4}{8h^2 \epsilon_0^2} \right\} = -\frac{13.6}{n^2} \text{ eV}$ <p style="text-align: right;">energy level equation for hydrogen atom</p> $\lambda = \frac{h}{p} = \frac{h}{mv}$ <p style="text-align: right;">de Broglie formula</p> $\theta \approx \frac{1.22\lambda}{d}$ <p style="text-align: right;">Rayleigh criterion (resolving power)</p>	<p><b>Medical Physics</b></p> $\theta \approx \frac{1.22\lambda}{d}$ <p style="text-align: right;">Rayleigh criterion (resolving power)</p> $\text{power} = \frac{1}{f}$ <p style="text-align: right;">power of a lens</p> $L = 10 \log \frac{I}{I_0}$ <p style="text-align: right;">intensity level (dB)</p> $Z = \rho c$ <p style="text-align: right;">acoustic impedance</p> $\alpha = \frac{I_r}{I_0} = \frac{(Z_2 - Z_1)^2}{(Z_2 + Z_1)^2}$ <p style="text-align: right;">intensity reflection coefficient</p> $I = I_0 e^{-\mu x}$ <p style="text-align: right;">transmitted intensity through a medium</p>

A1.	$E = mc \Delta T$	energy transfer during heating and cooling	D1.	$F = \frac{Q_1 Q_2}{4\pi\epsilon_0 r^2}$	Coulomb's law
A2.	$E = I \Delta m$	energy transfer during change of state	D2.	$E = \frac{Q}{4\pi\epsilon_0 r^2}$	electric field strength due to a point charge
A3.	$pV = nRT$	equation of state for an ideal gas	D3.	$V = \frac{Q}{4\pi\epsilon_0 r}$	electric potential due to a point charge
A4.	$pV = \frac{1}{3} Nmc^2$	kinetic theory equation	D4.	$E = \frac{V}{d}$	electric field between parallel plates (numerically)
A5.	$E_k = \frac{3RT}{2N_A}$	molecular kinetic energy	D5.	$I = nAvQ$	general current flow equation
B1.	$F = m \frac{\Delta v}{\Delta t} = \frac{\Delta p}{\Delta t}$	force	D6.	$R = \frac{\rho l}{A}$	resistance and resistivity
B2.	moment = $F \times d$	moment of a force	D7.	$R = R_1 + R_2$	resistors in series
B3.	$E_p = mgh$	gravitational potential energy	D8.	$\frac{1}{R} = \frac{1}{R_1} + \frac{1}{R_2}$	resistors in parallel
B4.	$E_k = \frac{1}{2} mv^2$	kinetic energy	D9.	$P = IV = I^2 R$	power in a circuit
B5.	$P = Fv$	mechanical power	D10.	$F = BQv \sin \theta$	force on a moving charge in a magnetic field
B6.	$a = \frac{v^2}{r} = \omega^2 r$	centripetal acceleration	D11.	$F = BIl \sin \theta$	force on a current-carrying conductor in a magnetic field
B7.	$F = \frac{Gm_1 m_2}{r^2}$	Newton's law of gravitation	D12.	$V = \frac{BI}{nQt}$	Hall voltage
C1.	$\Delta y = \frac{\lambda D}{a}$	fringe width in double-slit interference	D13.	$B = \frac{\mu_0 I}{2\pi r}$	magnetic field due to a long straight wire
C2.	$d \sin \theta = n\lambda$	diffraction grating equation	D14.	$B = \frac{\mu_0 NI}{l}$	magnetic field inside a long solenoid
C3.	$\frac{1}{u} + \frac{1}{v} = \frac{1}{f}$	equation for a single lens	D15.	$\mathcal{E} = N \frac{\Delta \Phi}{\Delta t}$	induced e.m.f.
			D16.	$\frac{V_s}{V_p} \approx \frac{N_s}{N_p}$	ratio of secondary voltage to primary voltage in a transformer
			E1.	$N = N_0 e^{-kt}$	law of radioactive decay
			E2.	$t_{\frac{1}{2}} = \frac{\ln 2}{k}$	half-life and decay constant
			E3.	$A = kN$	activity and the number of undecayed nuclei
			E4.	$\Delta E = \Delta mc^2$	mass-energy relationship