

## PHYSICS PAPER 1

8.30 am – 11.00 am (2½ hours)

This paper must be answered in English

### GENERAL INSTRUCTIONS

- (1) There are **TWO** sections, A and B, in this Paper. You are advised to finish Section A in about 60 minutes.
- (2) Section A consists of multiple-choice questions in this question paper, while Section B contains conventional questions printed separately in Question-Answer Book **B**.
- (3) Answers to Section A should be marked on the Multiple-choice Answer Sheet while answers to Section B should be written in the spaces provided in Question-Answer Book **B**. **The Answer Sheet for Section A and the Question-Answer Book for Section B will be collected separately at the end of the examination.**
- (4) The diagrams in this paper are **NOT** necessarily drawn to scale.
- (5) The last two pages of this question paper contain a list of data, formulae and relationships which you may find useful.

---

### INSTRUCTIONS FOR SECTION A (MULTIPLE-CHOICE QUESTIONS)

- (1) Read carefully the instructions on the Answer Sheet. After the announcement of the start of the examination, you should first stick a barcode label and insert the information required in the spaces provided. No extra time will be given for sticking on the barcode label after the 'Time is up' announcement.
- (2) When told to open this book, you should check that all the questions are there. Look for the words '**END OF SECTION A**' after the last question.
- (3) All questions carry equal marks.
- (4) **ANSWER ALL QUESTIONS.** You are advised to use an HB pencil to mark all the answers on the Answer Sheet, so that wrong marks can be completely erased with a rubber. You must mark the answers clearly; otherwise you will lose marks if the answers cannot be captured.
- (5) You should mark only **ONE** answer for each question. If you mark more than one answer, you will receive **NO MARKS** for that question.
- (6) No marks will be deducted for wrong answers.

**Section A**

**There are 36 questions. Questions marked with \* involve knowledge of the extension component.**

1. Two metal blocks  $X$  and  $Y$  of the same mass and of initial temperatures  $40^{\circ}\text{C}$  and  $30^{\circ}\text{C}$  respectively are in good thermal contact as shown. The specific heat capacity of  $X$  is greater than that of  $Y$ . Which statement is correct when a steady state is reached? Assume no heat loss to the surroundings.

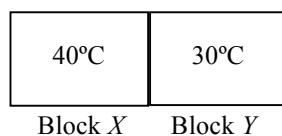

- A. The temperature of block  $X$  is higher than that of block  $Y$ .  
 B. Their temperature becomes the same and is lower than  $35^{\circ}\text{C}$ .  
 C. Their temperature becomes the same and is higher than  $35^{\circ}\text{C}$ .  
 D. Their temperature becomes the same and is equal to  $35^{\circ}\text{C}$ .
2. When a patient's arm is wiped by a piece of cotton soaked with alcohol, the wiped area will feel cool as that patch of alcohol on the skin evaporates. Which statement explains this phenomenon?
- A. The evaporation of alcohol absorbs heat from the patient's arm.  
 B. The alcohol on the skin releases latent heat to the surrounding air.  
 C. The motion of all the molecules in the patch of alcohol slows down.  
 D. Air molecules remove heat from the patch of alcohol by conduction.
- \*3. An ideal gas is contained in a closed vessel of fixed volume. The graph below shows the variation of pressure  $p$  of the gas against its Celsius temperature  $\theta$ .

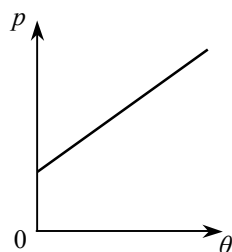

If the number of gas molecules in the vessel is halved, which graph of the dotted line best shows the relationship between  $p$  and  $\theta$ ?

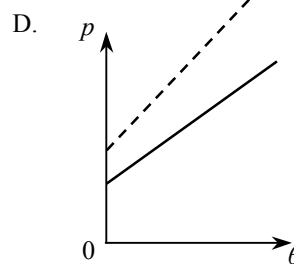
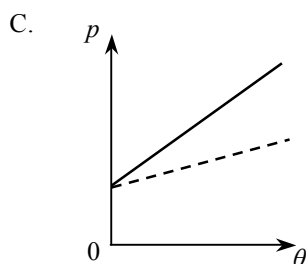
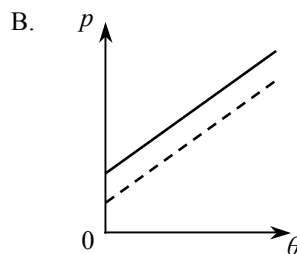
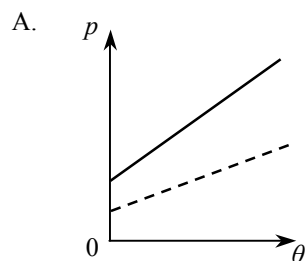

4. Which of the following descriptions is correct ?
- A. When water at  $25^{\circ}\text{C}$  is heated to  $50^{\circ}\text{C}$ , both the kinetic energy and potential energy of the water molecules increase.
  - B. When water at  $25^{\circ}\text{C}$  is heated to  $50^{\circ}\text{C}$ , only the potential energy of the water molecules increases.
  - C. When water boils at  $100^{\circ}\text{C}$  and turns into steam, the kinetic energy of the water molecules increases.
  - D. When water boils at  $100^{\circ}\text{C}$  and turns into steam, the potential energy of the water molecules increases.

5.

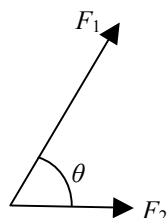

Two forces  $F_1$  and  $F_2$  of constant magnitudes act at the same point as shown. When the angle  $\theta$  between  $F_1$  and  $F_2$  increases from  $0^{\circ}$  to  $180^{\circ}$ , the magnitude of the resultant force

- A. decreases throughout.
  - B. increases throughout.
  - C. decreases and then increases.
  - D. increases and then decreases.
6. A uniform gangplank  $PQ$  of a ferry smoothly hinged at end  $P$  initially rests horizontally on the pier. The gangplank has mass  $M$  and length 2 m. It is raised by a man on the ferry using a light rope passing a smooth fixed light pulley and connecting to  $R$  on the gangplank as shown.  $R$  is 1.5 m from end  $P$ . Which of the following correctly describes the force required to raise the gangplank steadily ?

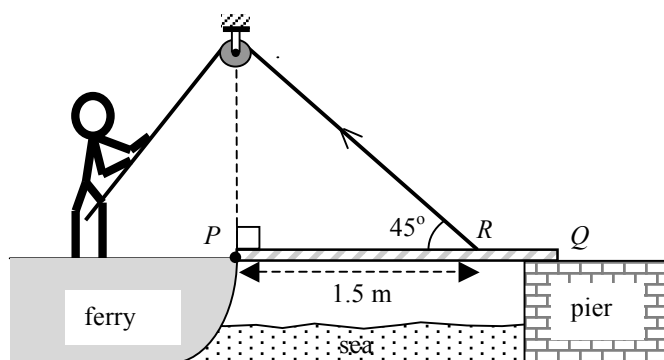

- |    | <i>initial</i> force required to raise the gangplank when it is horizontal | <i>subsequent</i> force required to raise the gangplank |
|----|--|---|
| A. | $0.67 Mg$  | greater than $0.67 Mg$                                  |
| B. | $0.67 Mg$  | smaller than $0.67 Mg$                                  |
| C. | $0.94 Mg$  | greater than $0.94 Mg$                                  |
| D. | $0.94 Mg$  | smaller than $0.94 Mg$                                  |

7. Which of the following graphs (velocity-time and displacement-time) best represent the motion of a ball falling from rest under gravity at a height  $H$  and bouncing back from the ground two times? Assume that the collision with the ground is perfectly elastic and neglect air resistance. (Downward measurement is taken to be negative.)

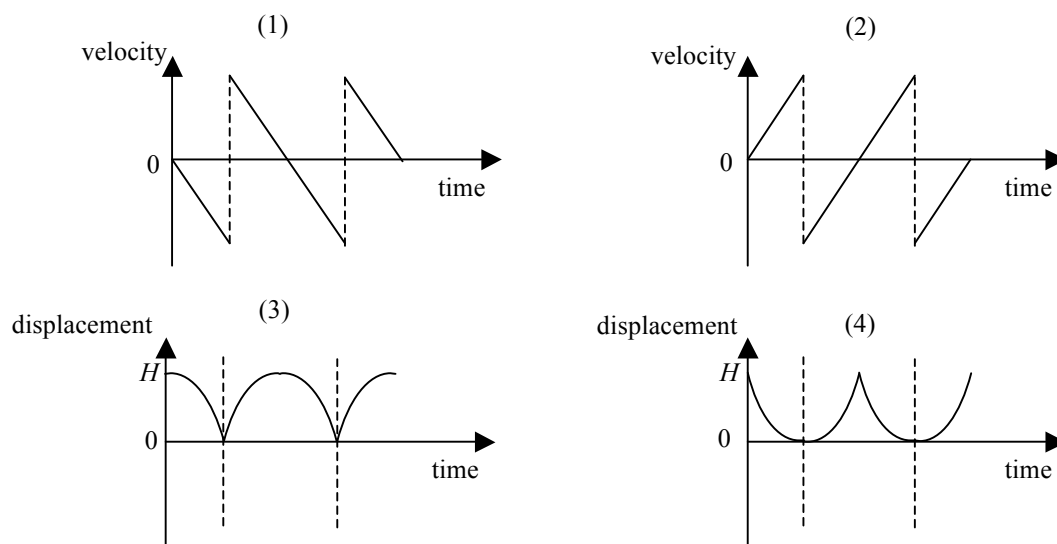

- A. (1) and (3) only  
 B. (1) and (4) only  
 C. (2) and (3) only  
 D. (2) and (4) only

- 8.

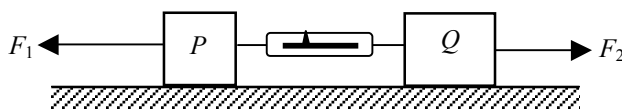

Blocks  $P$  and  $Q$  of mass  $m$  and  $2m$  respectively are connected by a light spring balance and placed on a smooth horizontal surface as shown. If horizontal forces  $F_1$  and  $F_2$  (with  $F_1 > F_2$ ) act on  $P$  and  $Q$  respectively and the whole system moves to the left with constant acceleration, what is the reading of the spring balance?

- A.  $\frac{2F_1 - F_2}{3}$   
 B.  $\frac{2(F_1 - F_2)}{3}$   
 C.  $\frac{2F_1 + F_2}{3}$   
 D.  $\frac{F_1 + 2F_2}{3}$

9. An object of mass  $0.5 \text{ kg}$  is raised vertically from the ground by a motor. The object is raised  $2.5 \text{ m}$  in  $1.5 \text{ s}$  with uniform speed. Estimate the output power of the motor. Neglect air resistance. ( $g = 9.81 \text{ m s}^{-2}$ )

- A.  $5.5 \text{ W}$   
 B.  $8.2 \text{ W}$   
 C.  $11.0 \text{ W}$   
 D.  $16.4 \text{ W}$

10. A block of mass  $m$  resting on a  $30^\circ$  incline is given a slight push and slides down the incline with a uniform speed. Which of the following statements about the block's motion on the incline is/are correct?

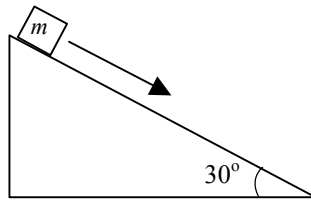

- (1) There is no net force acting on the block.  
 (2) The frictional force acting on the block is  $0.5 mg$ .  
 (3) If the block is given a greater initial speed, it will slide down the incline with acceleration.

- A. (1) only  
 B. (3) only  
 C. (1) and (2) only  
 D. (2) and (3) only

- 11.

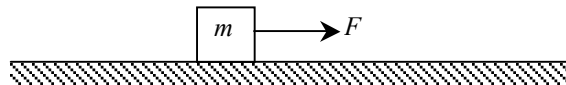

A block of mass  $m$  initially resting on a rough horizontal surface is pulled along the surface by a horizontal force  $F$  increasing from zero. If the frictional force is constant, which graph shows the relation between the acceleration of the block  $a$  and force  $F$ ?

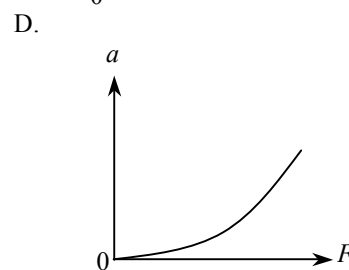
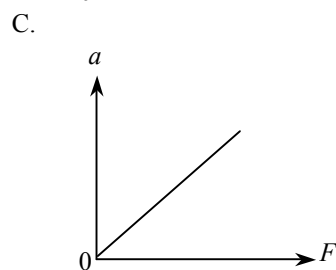
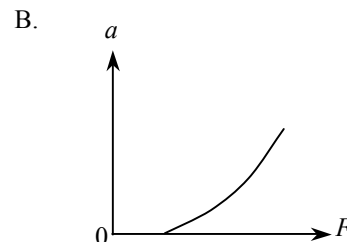
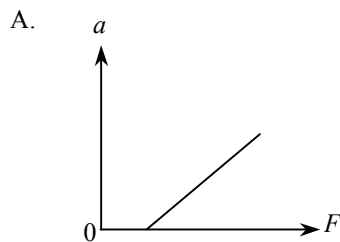

- \*12. A bomber aircraft is 1 km above the ground and is flying horizontally at a speed of  $200 \text{ m s}^{-1}$ . The aircraft is going to release a bomb to destroy a target on the ground. How long before flying over the target should the bomb be released? Assume that the bomber aircraft and the target are in the same vertical plane and neglect air resistance. ( $g = 9.81 \text{ m s}^{-2}$ )

- A. 5.6 s  
 B. 10.1 s  
 C. 14.3 s  
 D. It cannot be calculated as the horizontal distance between the aircraft and the target is not known.

13. On a smooth horizontal surface, a circular disk  $P$  moving at velocity  $u$  along the  $x$  direction collides obliquely with an identical disk  $Q$  initially at rest as shown below. The mass of each disk is  $m$ . Which statements about the collision is/are correct?

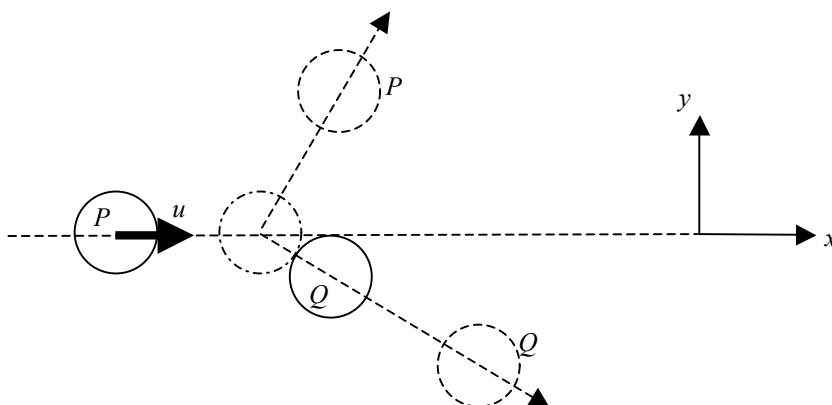

- (1) Momentum of the system in the  $y$  direction is not conserved.  
 (2) The total kinetic energy of  $P$  and  $Q$  after collision is  $\frac{1}{2}mu^2$  if the collision is perfectly elastic.  
 (3) Speed of  $Q$  after collision is less than  $u$ .
- A. (1) only  
 B. (3) only  
 C. (1) and (2) only  
 D. (2) and (3) only

- \*14. Two satellites move in circular orbits of the same radius  $R$  around the Earth (mass  $M$ ). The orbits are in two different planes  $P$  and  $Q$  as shown. Plane  $P$  coincides with the Earth's equator while plane  $Q$  is inclined to the equator at  $\theta$ . Which statement is **INCORRECT**?

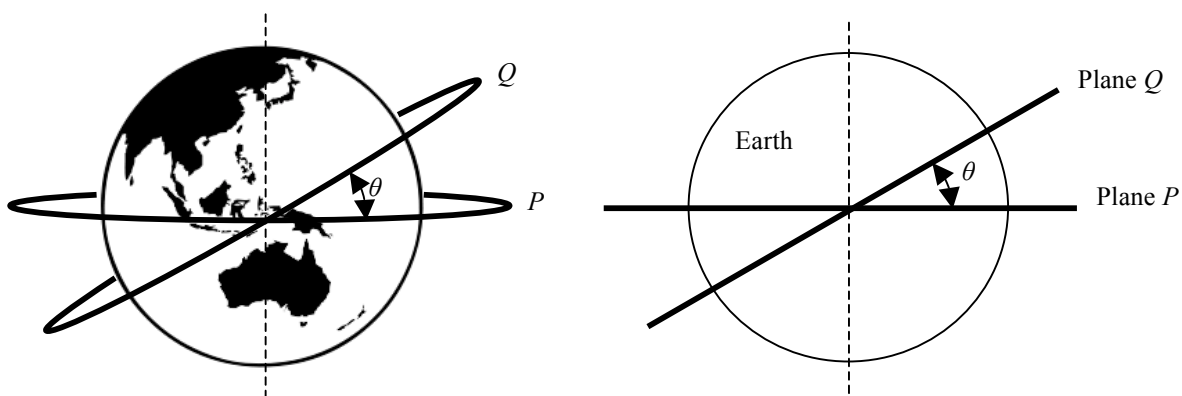

- A. The speed of satellite  $P$  is  $\sqrt{\frac{GM}{R}}$ .  
 B. The centripetal force acting on satellite  $Q$  is pointing along the plane  $Q$ .  
 C. The acceleration of both satellites is the same in magnitude.  
 D. The period of satellite  $Q$  is longer than that of satellite  $P$ .

15.

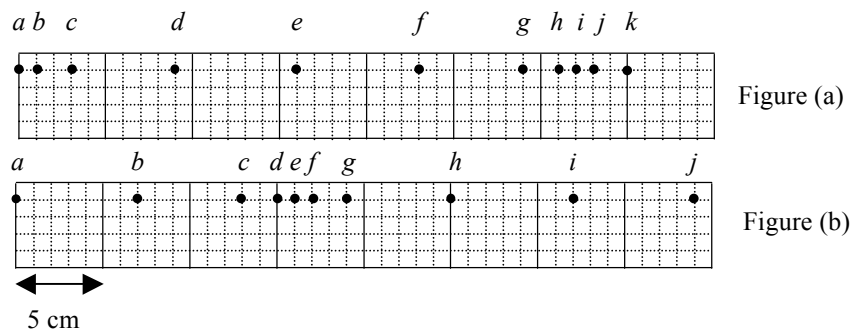

A series of particles is uniformly distributed along a slinky spring initially. Figure (a) shows their positions at a certain instant when a travelling wave propagates along the slinky spring from left to right. Figure (b) shows their positions 0.1 s later. Which statement is correct?

- A. Particle *e* is always stationary.
- B. Particles *a* and *i* are in phase.
- C. The wavelength of the wave is 16 cm.
- D. The frequency of the wave is 10 Hz.

16. A pulse on a string propagates towards the right end which is fixed.

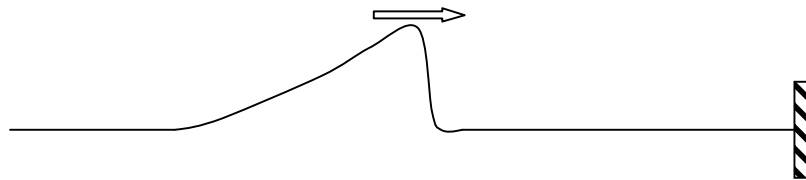

Which of the following represents the reflected pulse?

- A.
- B.
- C.
- D.

17. A certain monochromatic light passes through medium  $X$  as shown below. What is the refractive index of medium  $X$ ?

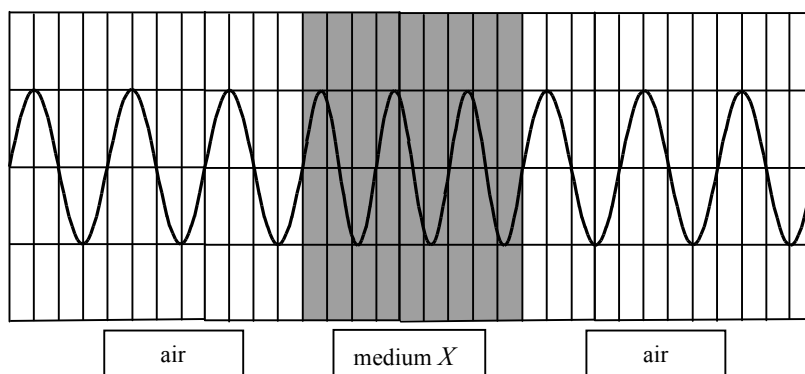

- A. 1.25  
 B. 1.33  
 C. 1.50  
 D. 1.65
18. A stationary wave is formed on a string fixed at both ends  $X$  and  $Y$ . The following is a snapshot of the string at time  $t = 0$ . The amplitude of vibration at an antinode is  $A$ .

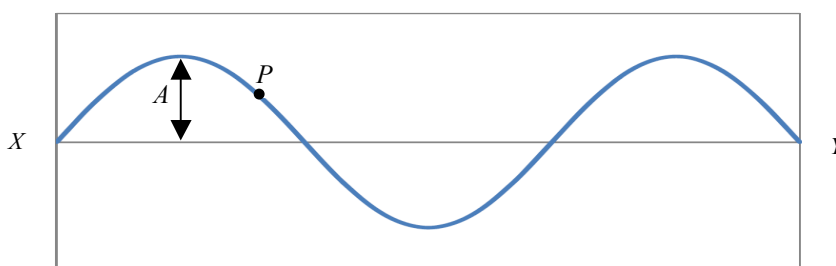

Which of the following shows the displacement-time graph of point  $P$  on the string for one period? (Upward displacement is taken as positive.)

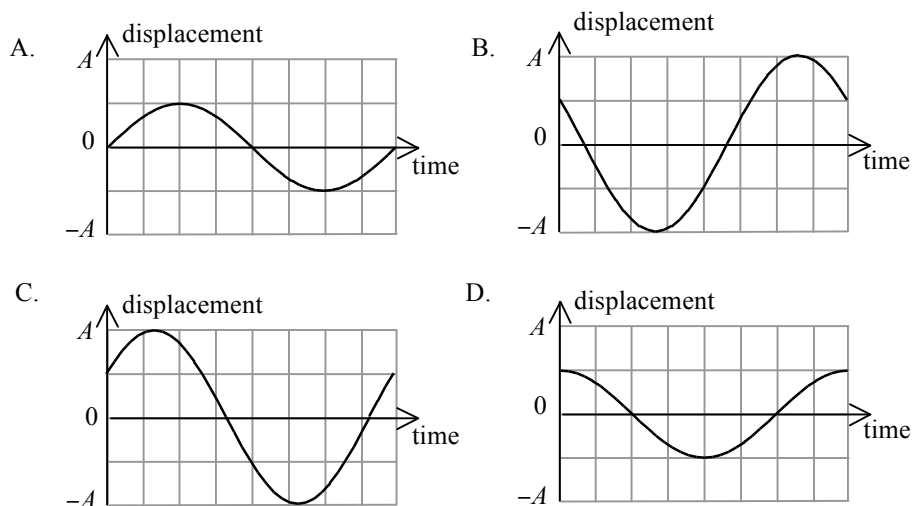

19. Which of the following statements is **INCORRECT**?
- A. In air, the wavelength of infra-red radiation is shorter than that of ultra-violet radiation.  
 B. Visible light travels faster in air than in glass.  
 C. Microwaves travel at the speed of light in a vacuum.  
 D. Both light and sound exhibit diffraction.



- \*20. For a diffraction grating of 600 lines per mm, the diffracted red light (657 nm) coincides with the diffracted violet light (438 nm) at angle of diffraction  $52^\circ$ . What are the respective orders of the diffracted red light and violet light ?

	red	violet
A.	2	3
B.	3	4
C.	3	2
D.	4	3

21. In each of the following diagrams,  $L$  is a concave lens and its two principal foci are denoted by  $F$  and  $F'$ . Which of the ray diagrams is/are possible ?

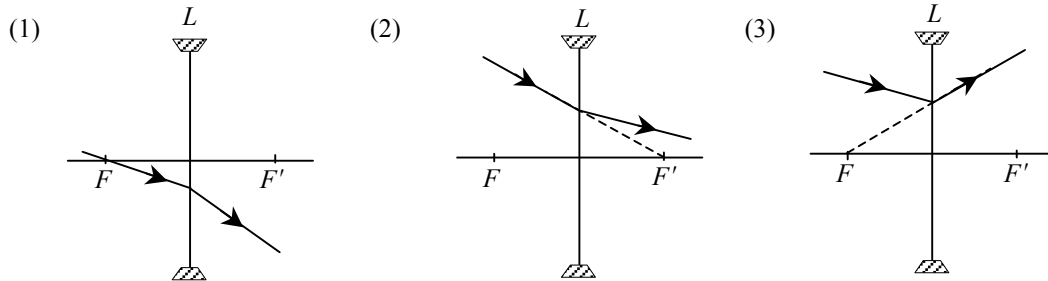

- A. (1) only  
 B. (3) only  
 C. (1) and (2) only  
 D. (2) and (3) only
22. The figure shows the waveforms of sound notes generated by a violin, a piano and a tuning fork. The scale is the same in time and intensity axes for all three waveforms.

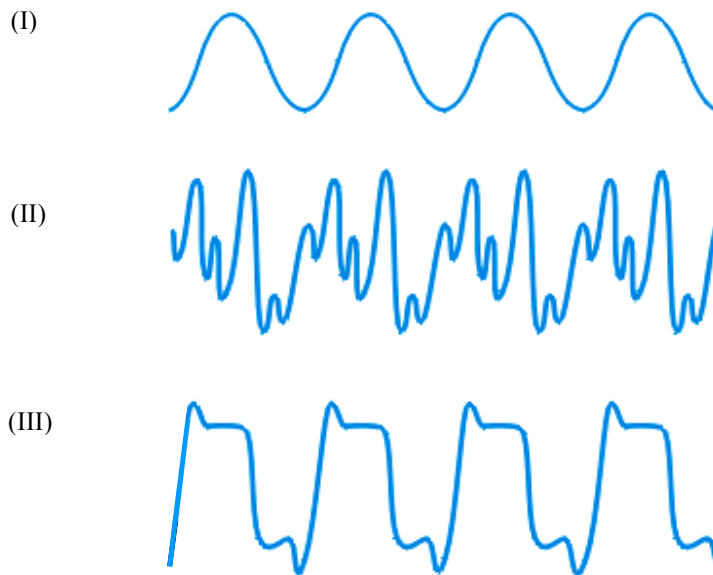

Which of the following about the sound notes are correct ?

- (1) They all have the same pitch.  
 (2) The qualities of sound of (II) and (III) are different.  
 (3) (I) is generated by the tuning fork.
- A. (1) and (2) only  
 B. (1) and (3) only  
 C. (2) and (3) only  
 D. (1), (2) and (3)

23. Which of the following about ultrasound is **INCORRECT** ?
- A. Ultrasound is a longitudinal wave.
  - B. The frequency of ultrasound is greater than 20000 Hz.
  - C. In air, the speed of ultrasound is faster than the speed of audible sound.
  - D. In air, the diffraction effect of ultrasound is less prominent than that of audible sound.

24.  $P, Q, R, S$  are charged objects. When two of them are brought close to each other,  $P$  and  $Q$  repel,  $R$  and  $S$  also repel while  $Q$  and  $R$  attract each other. Which of the following descriptions about their charges is/are possible ?

- (1)  $P$  and  $R$  are negatively charged.
- (2)  $Q$  and  $S$  are positively charged.
- (3)  $P$  is positively charged and  $S$  is negatively charged.

- A. (1) only
- B. (3) only
- C. (1) and (2) only
- D. (2) and (3) only

\*25.

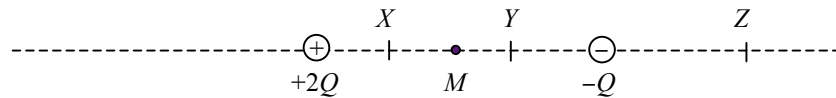

Two point charges  $+2Q$  and  $-Q$  are situated at fixed positions as shown.  $M$  is the mid-point between the charges.  $X, Y$  and  $Z$  are points marked on the line joining these two charges. At which point could

- (1) the resultant electric field due to the two charges be zero ?
- (2) the total electric potential due to the two charges be zero ?

- |    | (1) | (2) |
|----|-----|-----|
| A. | $Z$ | $X$ |
| B. | $Z$ | $Y$ |
| C. | $X$ | $Z$ |
| D. | $Y$ | $Z$ |

26.

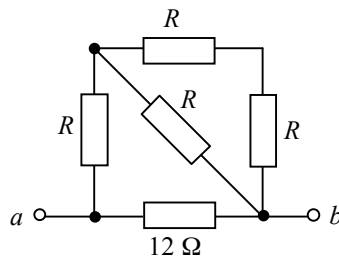

In the above network, the resistance across terminals  $a$  and  $b$  is  $6 \Omega$ . If the  $12 \Omega$  resistor is replaced by a  $6 \Omega$  resistor, the resistance across terminals  $a$  and  $b$

- A. becomes  $2 \Omega$ .
- B. becomes  $4 \Omega$ .
- C. becomes  $6 \Omega$ .
- D. cannot be found as the value of  $R$  is unknown.

27. What will happen if the variable resistor is set to zero in the circuit below ?

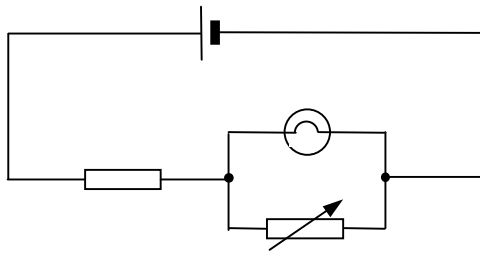

- A. The light bulb will burn out.  
 B. The light bulb will not light up.  
 C. The brightness of the light bulb will increase.  
 D. The brightness of the light bulb will remain unchanged.

- 28.

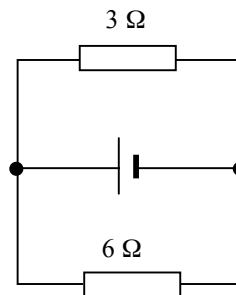

In the above circuit, the cell has e.m.f. 12 V and internal resistance 2 Ω. What is the current in the 6 Ω resistor ?

- A. 0.5 A  
 B. 1.0 A  
 C. 1.5 A  
 D. 2.0 A
29. In the figure below,  $X$ ,  $Y$  and  $Z$  are three long straight parallel wires with  $Z$  placed midway between  $X$  and  $Y$ .  $X$  and  $Z$  carry currents of 1 A in the same direction while  $Y$  carries a current of 3 A in the opposite direction. The magnetic force per unit length experienced by wire  $X$  due to wire  $Z$  is of magnitude  $F$ .

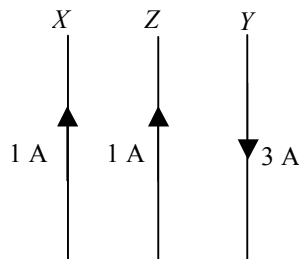

The magnetic force per unit length acting on wire  $Z$  due to both  $X$  and  $Y$  is

- A.  $2F$  to the right.  
 B.  $2F$  to the left.  
 C.  $4F$  to the right.  
 D.  $4F$  to the left.

30. An electron enters a region in which both a uniform electric field  $E$  and a uniform magnetic field  $B$  exist. The magnetic field  $B$  is pointing into the paper. In which direction should the electric field be applied so that the electron could be undeflected ?

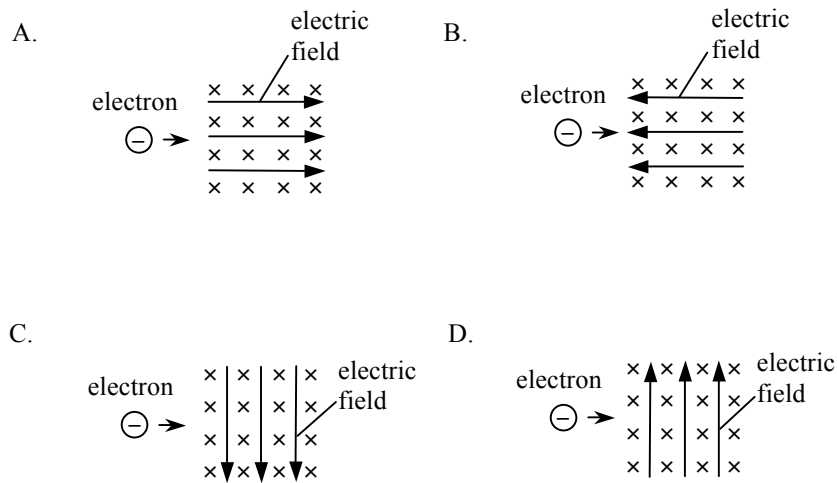

- 31.

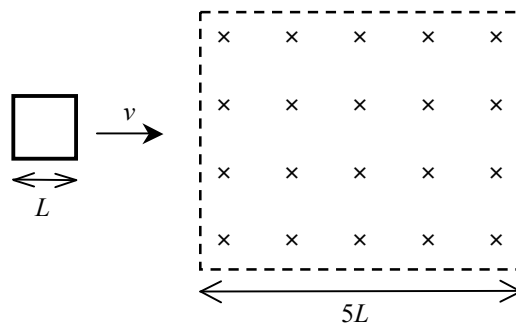

A square metal frame of length of side  $L$  moving with constant velocity  $v$  passes through a region of uniform magnetic field of width  $5L$  as shown. What is the total time period during which a current is induced in the frame ?

- A.  $\frac{L}{v}$   
 B.  $\frac{2L}{v}$   
 C.  $\frac{3L}{v}$   
 D.  $\frac{4L}{v}$

32. A copper rod  $PQ$  is placed horizontally as shown below. It is released and then falls vertically, cutting across the magnetic field of the Earth pointing out of the paper. Neglect air resistance. Which of the following statements is/are correct ?

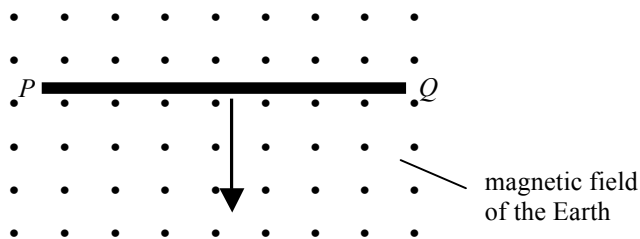

- (1) A voltage is induced across  $PQ$ .  
 (2) A steady induced current is generated in the rod.  
 (3) Due to the effect of the Earth's magnetic field, the copper rod falls with an acceleration less than the acceleration due to gravity.
- A. (1) only  
 B. (3) only  
 C. (1) and (2) only  
 D. (2) and (3) only

33.

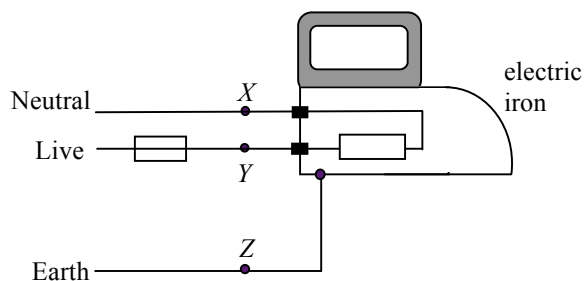

The figure shows a simple domestic circuit for an electric iron. The fuse will blow when which of the following points are short-circuited ?

- (1)  $X$  and  $Y$   
 (2)  $Y$  and  $Z$   
 (3)  $X$  and  $Z$
- A. (1) only  
 B. (3) only  
 C. (1) and (2) only  
 D. (2) and (3) only

34.

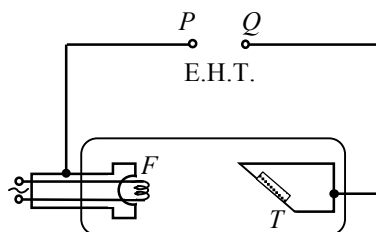

The figure shows a schematic diagram of an X-ray tube in which the filament  $F$  and the metal target  $T$  are connected to terminals  $P$  and  $Q$  of an E.H.T. Which statement is correct ?

- A.  $P$  is the positive terminal and X-rays are emitted from  $T$ .
- B.  $P$  is the positive terminal and X-rays are emitted from  $F$ .
- C.  $Q$  is the positive terminal and X-rays are emitted from  $T$ .
- D.  $Q$  is the positive terminal and X-rays are emitted from  $F$ .

35. A certain radioactive isotope  $X$  has a half-life of 20 hours. After a time interval of 10 hours, what is the approximate fraction ( $f$ ) of a sample of the radioactive isotope  $X$  remaining ?

- A.  $\frac{1}{4} \leq f \leq \frac{1}{2}$
- B.  $f = \frac{1}{2}$
- C.  $\frac{3}{4} > f > \frac{1}{2}$
- D.  $f > \frac{3}{4}$

36. Isotopes of an element have different mass number  $A$  and neutron number  $N$ . Which of the following  $N - A$  plots correctly shows the relationship of  $N$  and  $A$  for any given element ?

A.

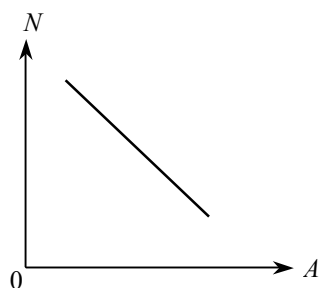

B.

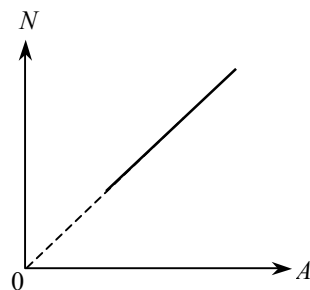

C.

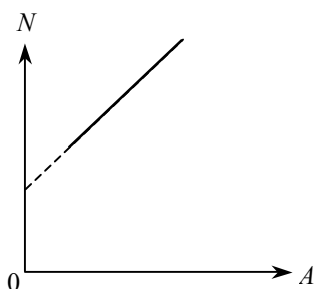

D.

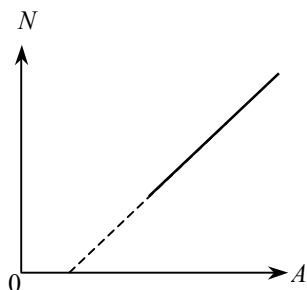

**END OF SECTION A**